

MODELS

RBA8851-137-PP
RBA8851-137-SS

BARIATRIC TOILET

Bariatric Toilet | Enviro-Glaze® White with Stainless Steel Internals
Bariatric Toilet | Stainless Steel



As improvements in the design and performance of RBA products are continuous, specifications may be subject to change without notice. The illustrations and descriptions herein are applicable to production as of the date of this Installation Instructions Sheet. Revised 02/23 © 2023 by RBA Group II/Model RBA8851-137/0223

Components Supplied

- P-trap stainless steel pan
- S-trap converter
- Security bit

Components Supplied By Others

- 12mm fixing rod
- Wall anchors
- M12 ground anchors

Pre-installation

Installation must be undertaken in accordance with the PCA (Plumbing Code of Australia) , AS/NZS3500.1 and AS/NZS3500.2. Where multiple WC's may be installed, correct hydraulic water supply sizing must be undertaken to ensure that each flushing device servicing each WC is able to operate correctly under probable simultaneous demand. A minimum water supply pressure of 300kPa is required for flushing device installation along with a minimum 25mm Cu or equivalent water supply line size for single flushing device installation only.

Pan is wall faced and should preferably be fixed to a masonry wall with suitable wall anchors provided by others.

Flushing device should be:

Fowler Tasman Mk 2 [or Stylus Symphony] cistern

Caroma Invisi II [in ceiling mount recommended]

RBA's 'Nautilus' Dual Flush Valve Incl Large Mounting Plate [see RBA1882-100-001]

Installation

1. Check supplied toilet against rough-ins provided in the installation instructions.
2. Remove access panels and place them in a safe area. Make sure to identify the access panels to the toilet they are removed from.
3. If not pre-formed, make sufficient penetrations through the wall and/or floor, as determined from the drawing, to allow for the 100mm waste pipe and flush pipe as provided by the cistern or flush valve manufacturer.
 - a. If rear fixed, M12 fixing rods [by others] to pass through.
 - b. If front fixed, use suitable wall anchors [by others] in the rear and floor of the toilet.
4. Determine floor mounting location by mocking up.
5. For P-trap configurations, fit a 100mm pan collar to the outlet with sufficient 100mm pipe to extend through the wall. Alternatively the waste and flush pipes may be pre-plumbed and the pan pushed onto the pipework.
6. For S-trap configurations, location of floor penetration should be centred 220mm from finished wall.
7. Similarly fit a 55mm Kee seal [by others] to the pan inlet with sufficient pipe, as provided by the cistern manufacturer, to extend through the wall.
8. Push the pan into position and secure the pan to the wall & floor [fixings by others].
9. Make the necessary connections to the waste and install the cistern and connect according to the manufacturer's instructions.
10. Check for leaks and correct flush volumes, 6 litres full flush and 3 litres half flush.
11. Unscrew plug bolts and fit the seat to pre-drilled holes and replace the access panels.

Dimensions and Rough-Ins

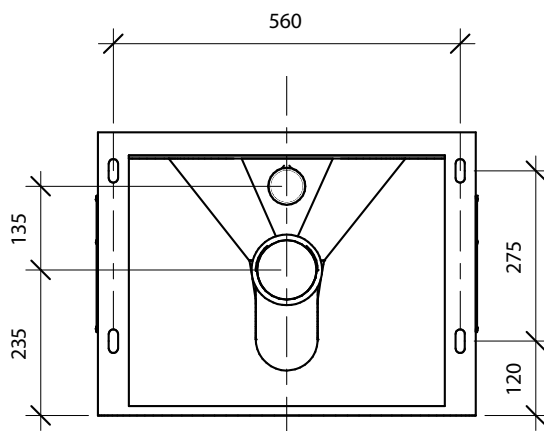
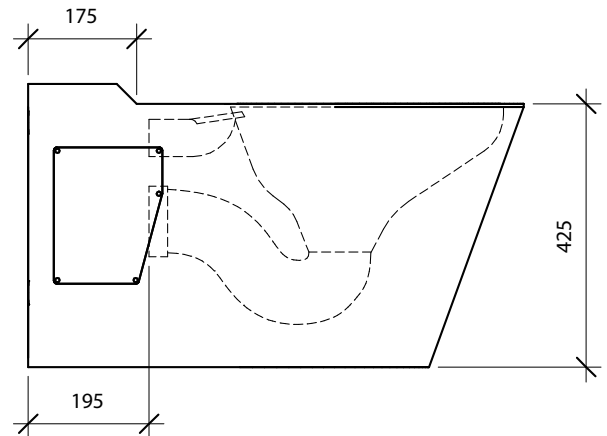
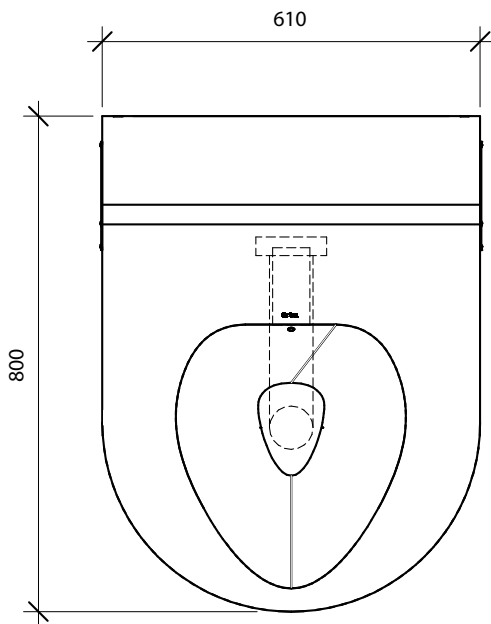

For best results, unit should be inspected and cleaned regularly as per the instructions in the RBA Product Warranty, Cleaning Care Guide, available on our websites.

Note: This product should be installed, by suitably qualified persons, in a fit for purpose application, to suitable materials, using suitable fixings and comply with any relevant codes. It should be inspected periodically for signs of wear and tear that may affect performance or safety.

Dimensions are subject to manufacturer's tolerance of +/-10mm. Rough-in should be completed with each fixture.

Important: Installation Instructions are subject to change without notice. Please visit **our websites** for latest revision.

