

Surface-Mounted Baby Changing Station

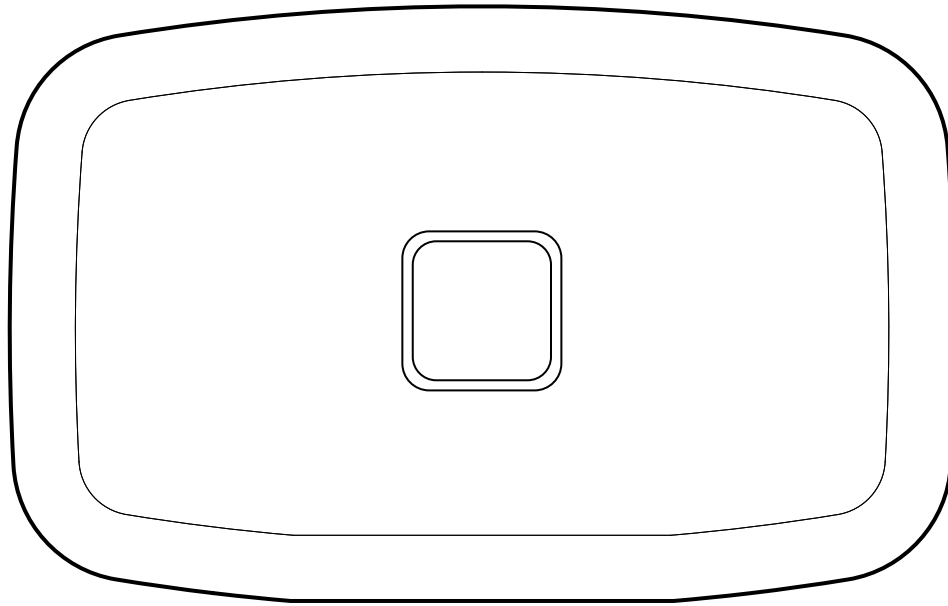

Important. Retain for future reference. Read carefully.

These Baby Changing Stations have been designed to meet the following applicable provisions of the 2010 ADA Standards (ADAS) and the 2009/2017 International Code Council (ICC) A117.1 Standards when properly installed and maintained. To comply with these accessibility requirements the unit must be installed in a compliant location and height in accordance with the installation instructions.

You are responsible for the safe operation of this unit.

Operations Instructions

Please Note

To assure proper installation, it is suggested that a qualified person or carpenter install the Baby Changing Station. RBA Australia will not be responsible if the station is not installed properly. These Baby Changing Stations have been tested to hold a substantial static load. The unit must be attached to a permanent wall that is capable of holding a substantial load. The maximum recommended total weight for this baby changing station (including baby and parcel bag) is 50 lb (22.7 kg). Excessive weight may cause a hazardous or unstable condition to exist.

Inspection Criteria

A properly maintained baby changing station:

- Opens and closes smoothly.
- Has a functioning strap and buckle. Strap is held firmly in place when buckle is depressed over it.
- Provides a clean, convenient place for customers to attend to their children.

Restraint System





Check strap by releasing the lever on the buckle and pulling one end of the strap up through the bottom of the buckle, depressing the lever when the strap is tight. Give the strap a tug in the horizontal direction away from the buckle, checking that the strap remains in place beneath the buckle. To loosen the strap, release the lever and pull the strap from the bottom of the buckle.

Cleaning and Maintenance

We recommend that the surface of the unit be cleaned prior to disinfecting. Use a clean nylon brush or a rag to loosen and remove soil from the textured surfaces. We

recommend that you use disinfectants and detergents that do not contain overwhelming fragrances that can mask inappropriate smells.

ASTM F2285-22 (2022)

-  **WARNING:** Never leave child unattended.
-  **WARNING:** Avoid serious injury from falling or sliding out. Always use restraint system.
-  **WARNING:** Designed for Infants Only. Age up to 3.5 years and weighing less than 50 lb (22.7 kg). Keep one hand on the child at all times.
-  **WARNING:** Parcels or accessory items, or both, placed on the unit may cause the unit to become unstable.

| | |
|---|---|
|  WARNING | |
|  WARNING | Never leave child unattended. |
|  WARNING | Avoid serious injury from falling or sliding out. Always use restraint system. |
|  WARNING | Designed for Infants Only. Age up to 3.5 years and weighing less than 50 lb (22.7 kg). Keep one hand on child at all times. |
| <small>Koala Kare Products, A Division of Bobrick 6982 S. Quentin Street Centennial, CO 80112 PH 888-733-3456 www.koalabear.com P/N 975</small> | |

Tools Needed

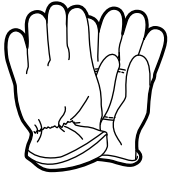

Safety Gloves

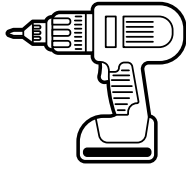

Drill

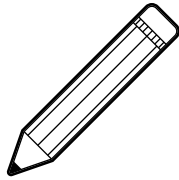

Pencil



Wall Stud Finder

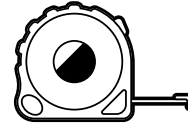

Measuring Tape

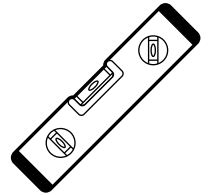

Level



Safety Glasses



Phillips Head
Screwdriver



1/8" (3mm)
(regular & masonry)
drill bits



7/32" (6mm)
(regular & masonry)
drill bits

Hardware Provided



1/4" x 3" (6.4mm x 76.2mm)
Pan Head Wood Screws
Quantity: 6

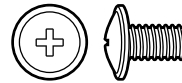

8-32" x 5/16" (7.9mm)
Flange Button Phillips Head Screws
Quantity: 2

Installation Instructions

Step 1:

- Inspect contents and remove changing station from the shipping container and check for any freight damage. If damage is found, please call RBA Australia at +1300 788 778.
- Identify the best location for installing the unit.

Step 2:

- Remove the bed and chassis from the box. Open the main unit by pulling up on the frame and remove the plastic liner dispenser. Set it to one side. **Fig. 1**
- Make sure you have taken into consideration the operating clearance of $8 \frac{15}{16}$ " (228mm) on both sides of the exposed chassis and $23 \frac{3}{16}$ " (589mm) from wall surface when open.

For Wood Stud Wall

- Measure from the floor $37 \frac{7}{16}$ " (951mm) on stud center and mark the wall. The mounting holes are designed for 16" (406mm) stud centers. Ensure the locations you have marked for the mounting holes are level before drilling. **Fig. 2** Drill pilot holes for keyhole mounting using a $\frac{1}{8}$ " regular drill bit.
- If the wall has wooden studs that are not on 16" (406mm) centers, you will need to use toggles to secure one side of the unit. The other side should be secured to the stud using the screws provided. You must allow for space inside the wall for the toggles to turn. This will vary depending on the toggles used.

For Masonry or Tile over Stud Wall

- Use a $\frac{7}{32}$ " (5mm) masonry drill bit for the pilot hole until you hit the stud. Change bit to $\frac{1}{8}$ " (3mm) regular drill bit.

For Metal Stud or Concrete Block

- If the wall has metal studs or an underlying surface of concrete block, you will need to use toggles to secure one side of the unit. The other side should be secured to the stud using the screws provided. You must allow for space inside the wall for the toggles to turn. This will vary depending on the toggles used.

Fig. 1

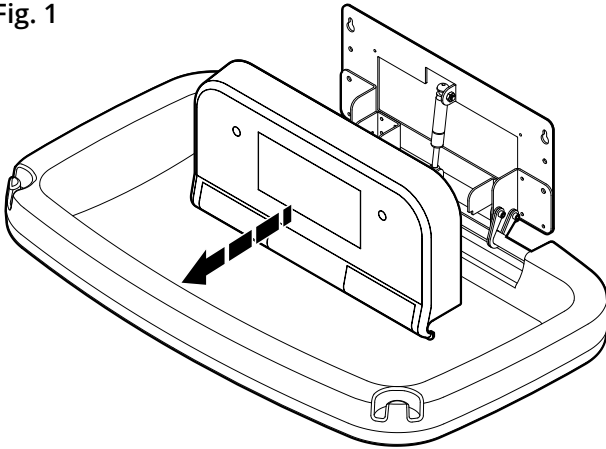
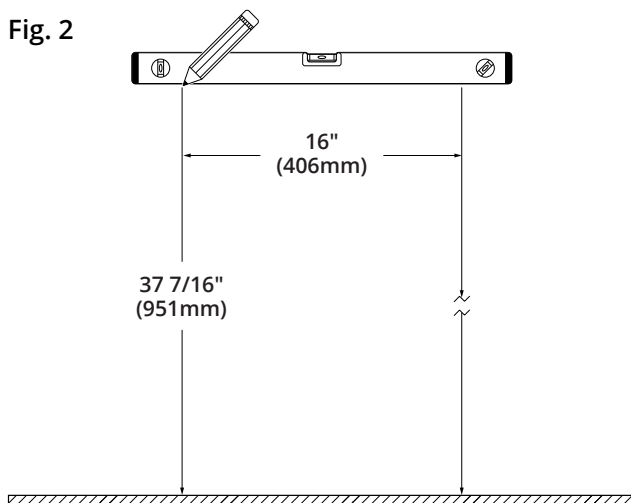

Fig. 2



*Diagrams are not to scale.

Fig. 3

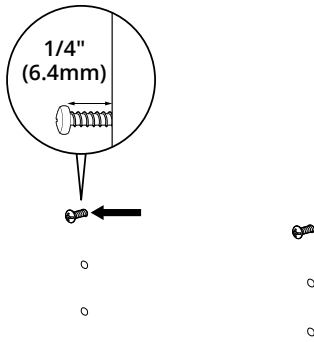

Fig. 4

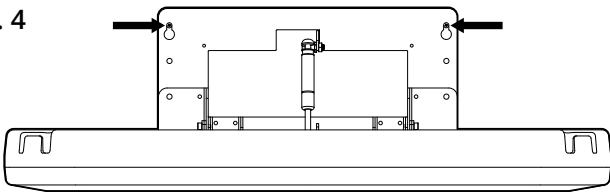

Fig. 5

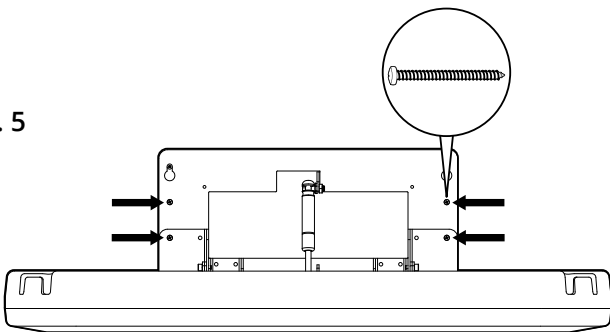
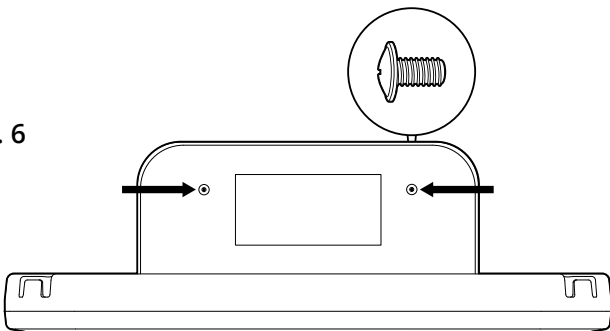

Fig. 6



Step 3:

- Mount bed and chassis by screwing two of the mounting screws into the pilot holes leaving 1/4" (6.4mm) exposed to allow keyhole slots to be easily mounted over the screw heads. **Fig. 3**
- Place chassis over screws. **Fig. 4**
- After securing the unit using the keyhole slots, verify that the unit is level. Tighten top two screws so that they are flush with the wall.
- Use the four lower holes as a guide to mark and drill pilot holes. Use remaining four screws and four washers to complete installation of bed and mounting bracket. Insert washers over lower four screws. **Fig. 5**
- All **six** screws and four washers must be properly mounted to the chassis.

Step 4:

- To install wall cover ensure wall cover is free from damage.
- Line up mounting holes onto chassis and secure with the two screws provided. **Fig. 6** Cover mounting holes with provided plugs.

Step 5:

- Clean work area and inspect unit to ensure it opens and closes smoothly.

RBA Australia
Tel: + 1300 788 778
Email: sales@rba.com.au
www.rba.com.au