

**MODEL WALL MOUNTED BASIN**

**RBA8864-100**

Wall Mounted Basin



As improvements in the design and performance of RBA products are continuous, specifications may be subject to change without notice. The illustrations and descriptions herein are applicable to production as of the date of this Installation Instructions Sheet. Revised 11/24 © 2024 by RBA Group II/Model RBA 8864-100/1124

## Components Supplied

- Basin complete with fixing brackets
- 40mm Waste Outlet

## Components Supplied By Others

- Tapware
- Wall anchors and fixings
- Trap

## Description

Wall mounted vandal resistant basin, fabricated from 1.3mm type 304 stainless steel. All exposed surfaces polished to a satin finish, and corners ground to a rounded surface.

Basin is supplied with in-built fixing brackets, single 35mm Ø punched tap hole [tapware by others] and single 55mm Ø punched waste hole to accept supplied 40mm waste outlet.

## Installation

1. Basin is vandal resistant and should be mounted on a suitable wall to support the unit, using the brackets provided and suitable wall anchors [by others]. Ensure that the basin is mounted level, and at the correct height.
2. For accessible/disabled installations, the basin should be mounted with the rim at 864mm above FFL. Reference should be made to AS1428.1 with regard to location, height, trap and tapware.
3. For non-accessible/disabled installations, we recommend mounting at a height suitable for the intended application.

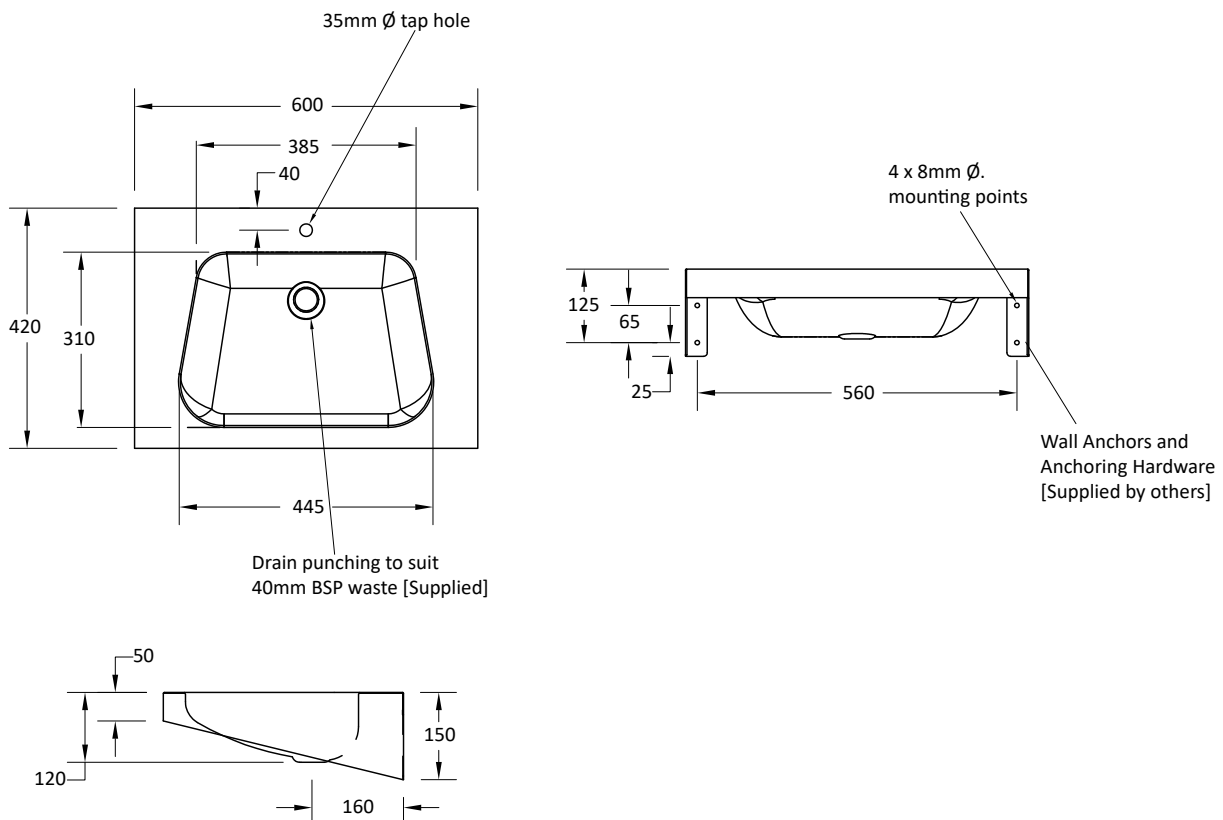

**Note:** This product should be installed, by suitably qualified persons, in a fit for purpose application, to suitable materials, using suitable fixings and comply with any relevant codes. It should be inspected periodically for signs of wear and tear that may affect performance or safety. Dimensions are subject to manufacturer's tolerance of +/-10mm. Rough-in should be completed with each fixture.

**Important:** Installation Instructions are subject to change without notice. Please visit [our websites](#) for latest revision.