

MODEL

RBA2731-COOLER MOUNTED SERIES

- RBA2731-500**
- RBA2731-502**
- RBA2731-503**

- H₂O-to-Go![™] Push Button Bottle Filler Add-On
- H₂O-to-Go![™] Bottle Filler Add-On with Bottle Counter Display [shown]
- H₂O-to-Go![™] Sensor Bottle Filler Add-On



As improvements in the design and performance of RBA products are continuous, specifications may be subject to change without notice. The illustrations and descriptions herein are applicable to production as of the date of this Installation Instructions Sheet. Revised 10/24 © 2024 by RBA Group II/Model RBA2731-5XX-Cooler-Mounted/1024

This product is to be installed in accordance with the Plumbing Code of Australia (NCC Vol. 3), AS/NZS3500.1 and AS/NZS3500.2 as well as any other applicable requirements subject to the jurisdiction under which the product may be installed. Please read the entirety of this booklet before commencing installation. Please leave this booklet with the owner of the fixture when finished.

Technical Data

Inlet Connection:	1/4" Push Fit Connection
Water Pressure:	200-500kPa
Water Temperature:	4-30°C
Flow rate:	3.8 LPM Laminar flow

Components Supplied

- Bottle filler assembly
- 9V transformer [sensor op. units only]
- 1/4" Tee pushfit
- Plastic collar

Dimensions

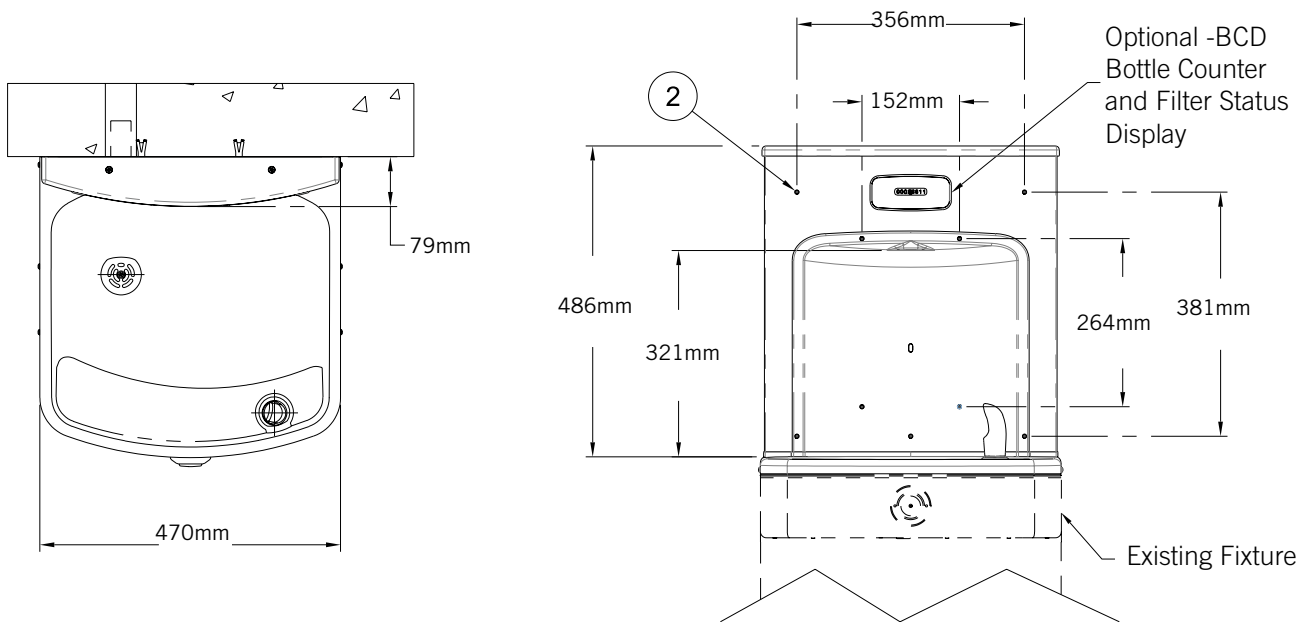

[RBA2731-502 shown]

Installation [All Units]

1. Install the newly obtained water cooler per the installation manual provided with the unit. Do not install access panel at this time. Shut-off water supply, then actuate valve to relieve pressure. Place screws and panel in secure location for further use in manual.

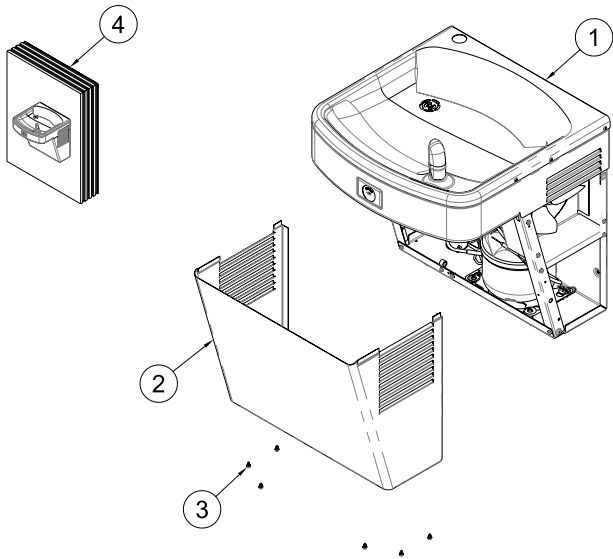

1. Water Cooler Assembly
2. Access Panel
3. Security Screw
4. Water Cooler Installation Manual

2. Remove bottle filler assembly, power supply and grommet from packaging, careful to avoid damage to fixture and fixture sub assemblies. Check supplied product against rough-ins provided in the installation instruction. Set power supply aside in a secure location

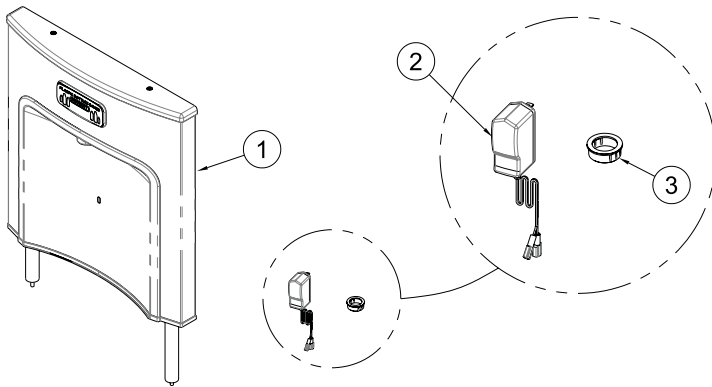

1. Bottle Filler Assembly
2. Power Supply [Not provided with push button series]
3. Locking Grommet

3. Unfasten screws that hold the bottle filler housing to the mounting panel. Place bottle filler panel and screws in a secure location.

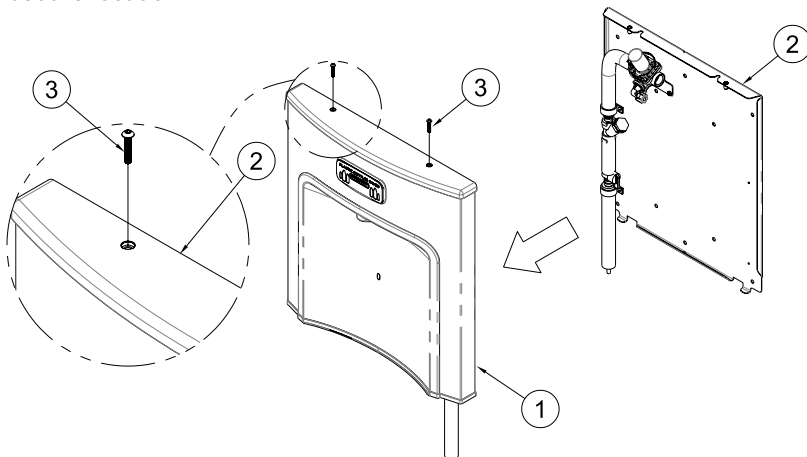

1. Bottle Filler Housing
2. Mounting Panel
3. Security screws

4. Disconnect the water supply insulation and tubing from 1/4" shut-off valve that is located on the mounting panel.

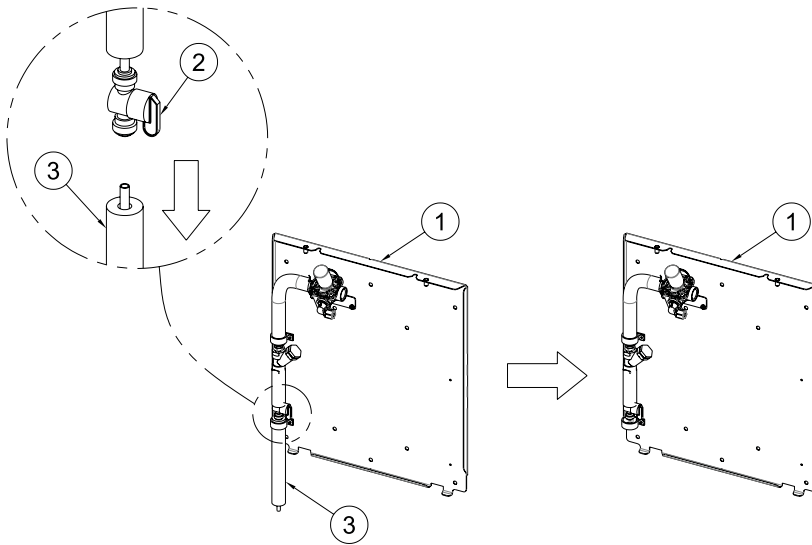

1. Mounting Panel
2. Shut-Off Valve
3. 1/4" OD Tubing & Insulation

5. Connect the bottle filler supply tubing to the 1/4" push-in tee located on the evaporator. The evaporator is located within the water cooler assembly. If fixture differs from layout, refer to Page 11 for specific unit connections.

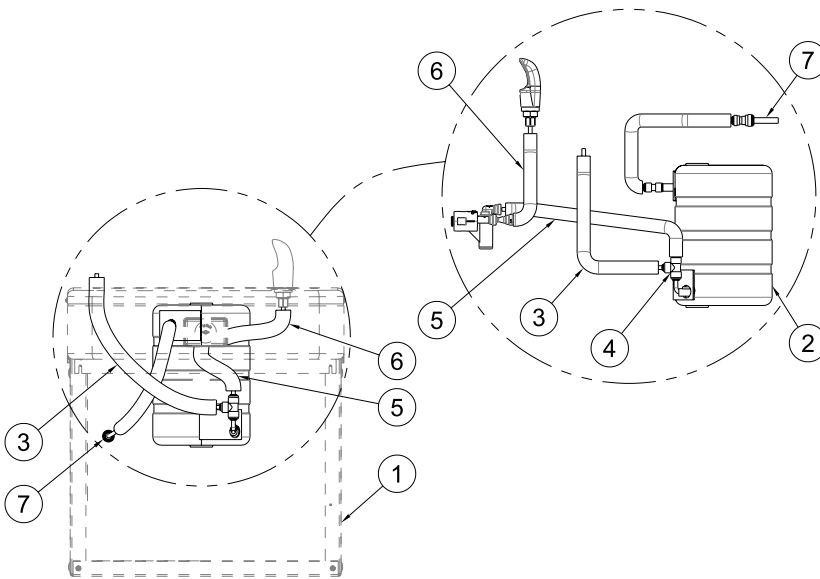

1. Water Cooler Assembly
2. Evaporator
3. 1/4" OD Tubing & Insulation [Bottle Filler Supply Tube]
4. 1/4" Push-In Tee
5. Water Supply Tubing [To Push Button Valve Inlet]
6. Water Supply Tubing [To Bubbler]
7. Supply Inlet

6. Centre mounting panel on top of deck to finished wall and secure with anchoring hardware [by others] for Ø1/4" mounting holes.

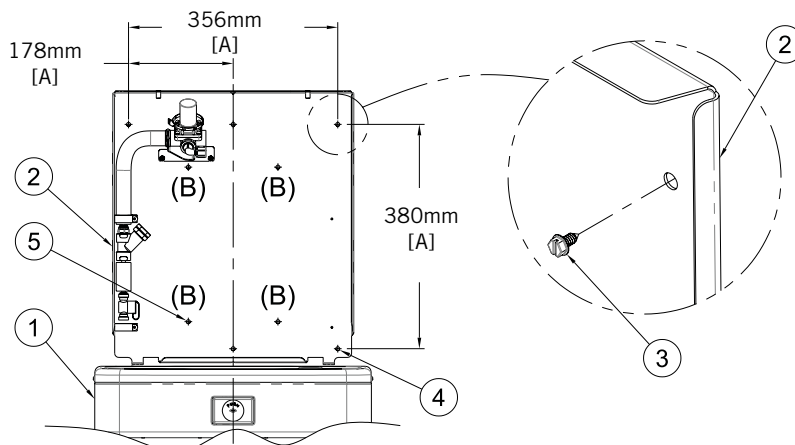

1. Water Cooler Assembly
2. Mounting Plate
3. Anchoring Hardware [by others]
4. 6x Ø1/4" Mounting Holes [A]
5. Ø6.5mm Mounting Holes [B]

7. Push tubing with insulation and power wires up through hole in basin. Install grommet.

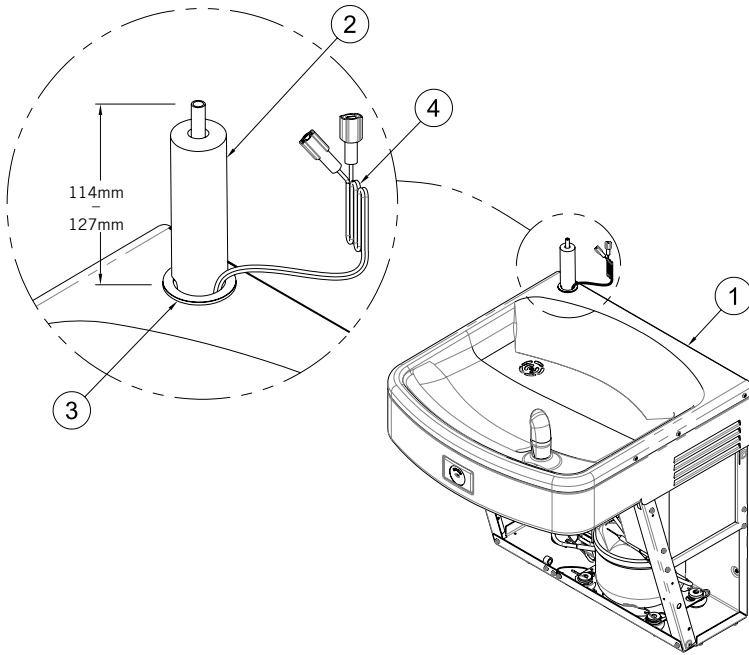

1. Water Cooler Deck
2. 1/4" OD Tubing & Insulation
3. Grommet
4. Power to Bottle Filler [Sensor Op units only]

8. Connect water supply tube to the 1/4" shut-off valve that is located on the mounting panel.

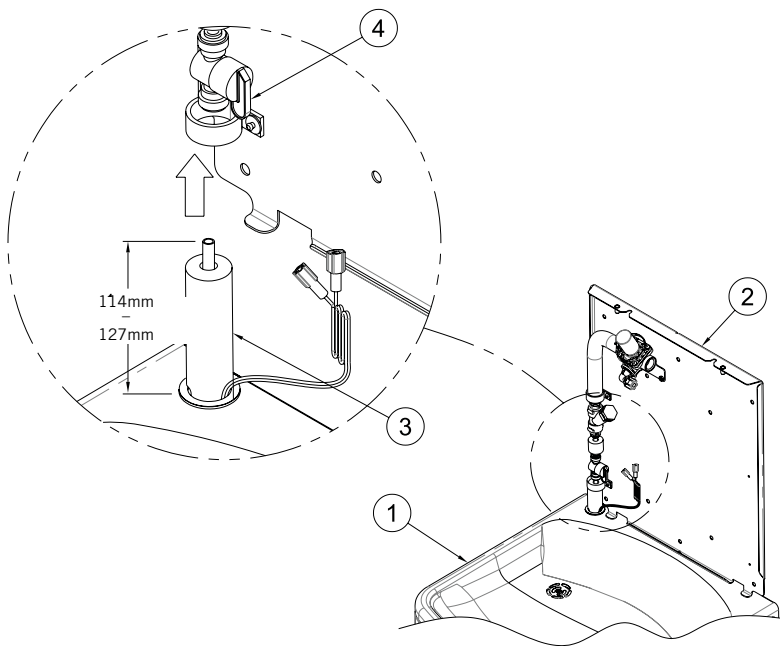

1. Water Cooler Deck
2. Mounting Plate
3. 1/4" OD Tubing & Insulation
4. Shut-Off Valve

Installation [RBA2731-500 only]

9. With mounting panel secured, place bottle filler housing on top of the water cooler and connect water supply line from bottle filler to pneumatic valve outlet. Connect 1/8" air-line to push button and pneumatic valve inlet. To continue, skip to Step 13, Page 7.

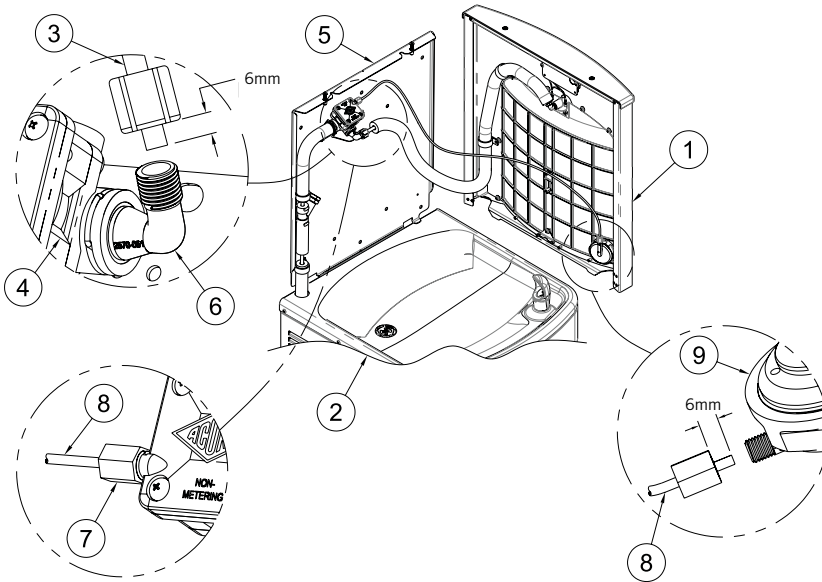

1. Bottle Filler Housing
2. Water Cooler Assembly
3. 1/4" O.D. Polyethylene Supply Line
4. Pneumatic Valve
5. Mounting Panel
6. Valve Water Supply Outlet Elbow
7. Valve Air-Line Supply Inlet
8. 1/8" O.D. Polyethylene Supply Line
9. Push Button

Installation [RBA2731-502 and RBA2731-503 only]

10. With mounting panel secured, place bottle filler housing on top of the water cooler and connect water supply line from bottle filler to solenoid valve outlet.

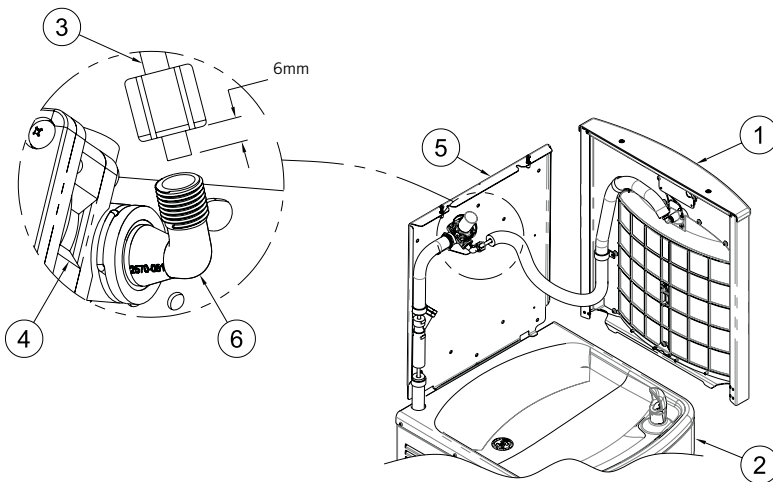

1. Bottle Filler Housing
2. Water Cooler Assembly
3. 1/4" O.D. Polyethylene Supply Line
4. Solenoid Valve
5. Mounting Panel
6. Valve Water Supply Outlet Elbow

11. Connect electrical wiring as shown in diagram. If unit does not have -BCD Bottle Count Display, skip to step 12

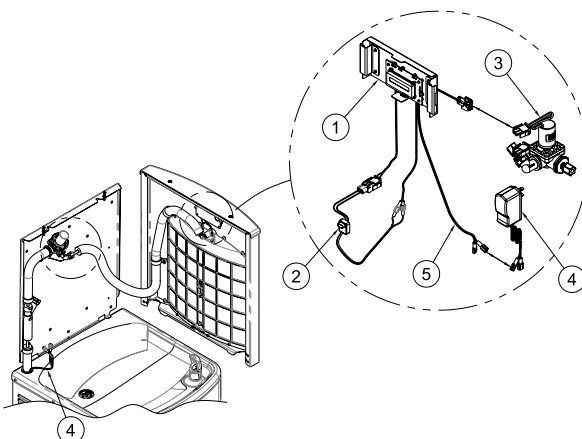

1. BCD Bottle Count Display
2. Sensor
3. Solenoid Valve
4. Power Supply
5. Black Wire - BCD

12. Connect electrical wiring as shown in diagram. If unit has -BCD Bottle Count Display, see step 11 before continuing.

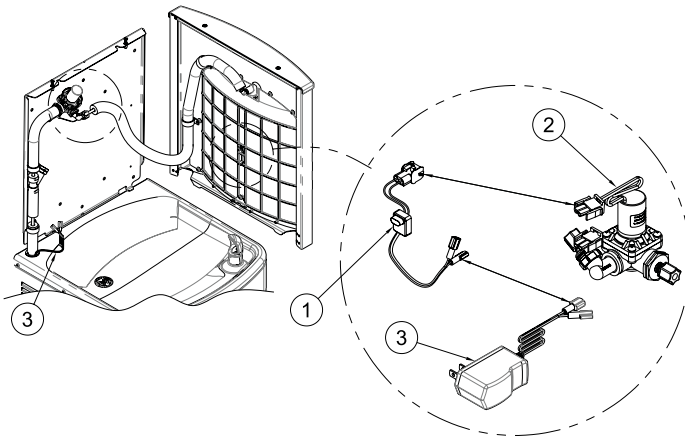

- 1. Sensor
- 3. Solenoid Valve
- 4. Power Supply

13. Connect power supply [if available], turn on water and check for leaks throughout the system.

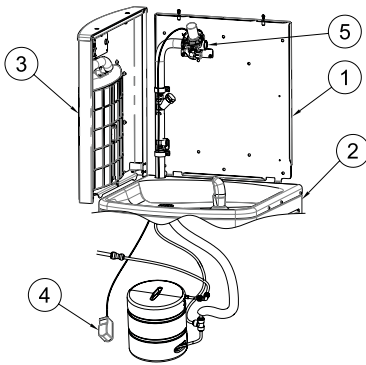

- 1. Mounting Panel
- 2. Water Cooler Assembly
- 3. Bottle Filler Housing
- 4. Power Supply
- 5. Solenoid Valve

14. With fixture tested, install housing to mounting panel. Angle housing and engage housing bottom flange to mounting panel flange and close unit. Secure with screws from step 3.

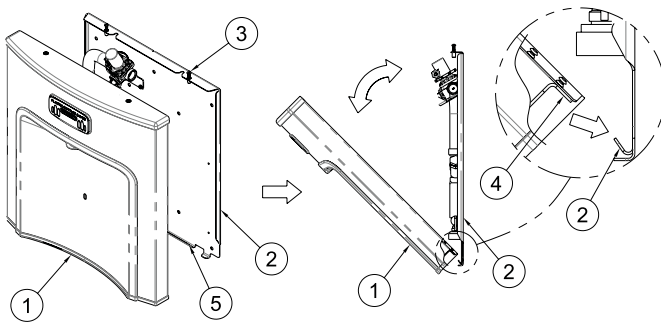

- 1. Bottle Filler Housing
- 2. Mounting Panel
- 3. Security Screws
- 4. Housing Bottom Flange
- 5. Mounting Panel Flange

15. Mount water cooler access panel to water cooler

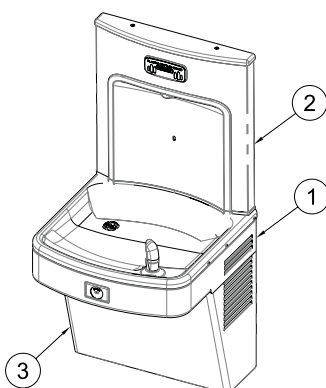

- 1. Water Cooler
- 2. Bottle Filler
- 3. Access panel

Electrical Installation

Note: Plug-in Power is a standard feature.

1. Plug-in operation: plug transformer provided into ELCB [RCD] protected electrical service, used by the bottle filler.
2. Connect the power supply wires to either the sensor or -BCD bottle counter display [if equipped].

Start up

Air within the bottle filler system or the structure supply piping will cause an irregular spout outlet stream until purged out by incoming water. Hold cup [or similar object] directly below filler spout is recommended when first activating bottle filler to prevent excessive splashing. Activate sensor until steady water stream is achieved.

Operating Instructions

Position container to be filled directly in front of the sensor and centered under the filler spout. Water flow starts automatically. When the container is almost filled, remove container. The water will stop flowing.

Bottle Counter Adjusting & Resetting Instructions

Note: Bottle counter has multiple functions

- Reset/ mode button
- Counts refilled bottles
- Adjustable for units with and without filters
- “Replacement filter” alert function
- Alert reset, when filter is replaced

Description

Illuminated LCD display counts bottles and has a filter replacement alert function.

Bottle Counting Function

The software applies a flow volume of approximately 500ml to each bottle counted. If the flow volume is less than 500ml, there will be no count but the volume will accumulate, so that part way through the next cycle the total bottle count will change.

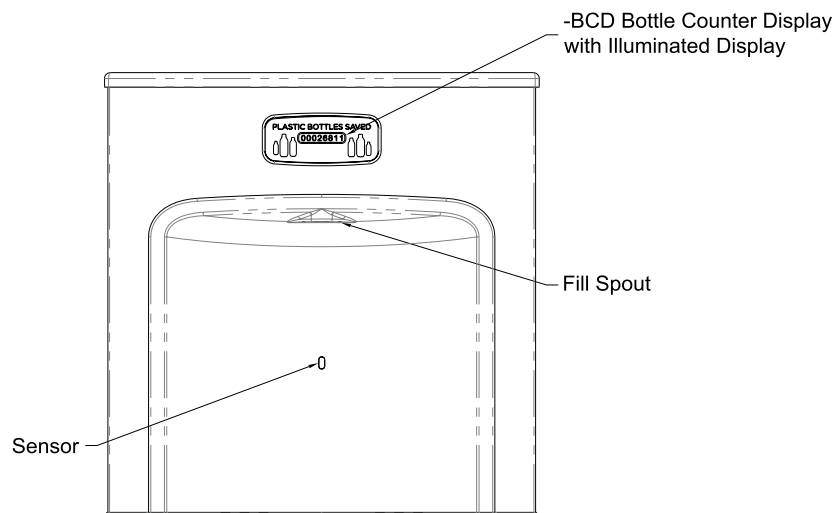

Filter Replacement Functions

Note: When the volume accumulates to Filter capacity, the “REPLACE FILTER SOON” alert will appear on the display every time the Bottle Filler is activated.

Counter Modes

Located on the back of the display you will find the Reset/Mode button for the mode settings. The Reset/Mode Selection Button is accessible by removing the Housing, then locate the large hole in the back of the Display Mounting Bracket. Use your finger or nonconductive object to depress the Reset/Mode Selection Button. **CAUTION:** do not use sharp or metal objects. With this Reset/Mode Button, you are able to indicate whether or not the unit has a Filter or does not have a Filter. The Reset/Mode Button is used to remove the “REPLACE FILTER” alert after the Filter has been replaced.

Systems With or Without Filter

- To reset “REPLACE FILTER” message:
Press and hold Button until “3” is displayed, then release.
- To change display to match Filter capacity:
Press and hold Button until the display matches installed Filter type, then release.

“FILTER NONE” “FILTER 1500” “FILTER 3000”

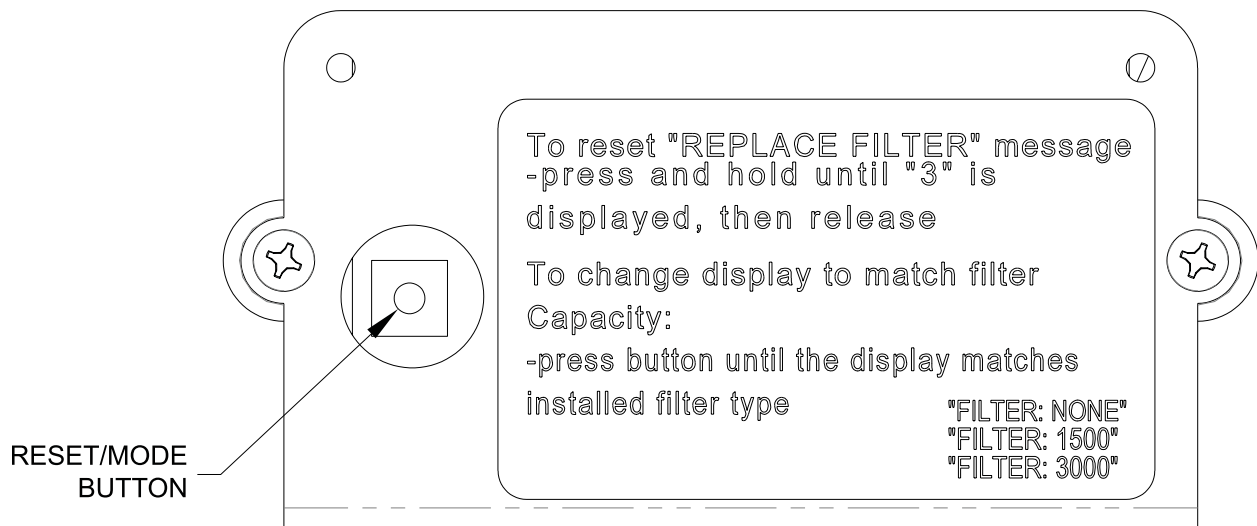

Troubleshooting

Problem	Solution
If light within sensor does not flash once when user is within range	<ul style="list-style-type: none"> a. Verify 240V AC input & 9VDC output of Transformer. b. Replace defective Transformer. c. Sensor in "Security Mode" after 20 seconds of constant detection. Remove source of detection and wait 30 seconds before checking. d. Sensor is picking up a highly reflective surface. Eliminate cause of reflection and wait 30 seconds before checking. e. Replace defective sensor.
If light within sensor lens flashes once when the user is within range	<ul style="list-style-type: none"> a. Repair bad connection from Sensor to Solenoid. b. There is debris or scale in the Solenoid assembly. Remove Solenoid, pull out Plunger and Spring. Clean with scale remover solution. c. There is debris or scale in center or two holes in convolution of the water diaphragm. Remove and clean.
Restricted or no water flow	<ul style="list-style-type: none"> a. Ensure Water Supply service stop valve is fully open. b. Verify minimum 200kPa supply line flow pressure. c. Check for twist or kinks in Spout Tubing. d. Check the water inlet "Y" Strainer. Sediment from the main supply can get trapped in the Screen along with installation materials such as pipe dope and flux. The Screen should be cleaned and checked on a regular basis and replace if needed. e. Flow Control in spout clogged, remove & clean. f. The Water Cooler may also develop a freezing condition in which the water will become frozen inside the Evaporator coil. This indicates a refrigeration problem or Thermostat failure in which case the Water Cooler needs to be checked by a qualified technician. g. No power to Transformer connections loose or wires cut.

Cleaning & Maintenance Guide

1. To remove water spots or rust spots, stainless steel cleaner/polish on a cloth is recommended.
2. If there are stubborn spots or if you wish to treat a scratch, synthetic abrasive general purpose pads such as Scotch-Brite® is recommended.
3. Apply stainless steel cleaner/polish to the synthetic abrasive pads and carefully rub the panel with the grain.
4. Do NOT use harsh chemicals, abrasive or petroleum based cleaners. Use of these will void RBA warranty. DO NOT use abrasives on powder coated units.
5. Stainless steel should be kept clean at all times. If a coating of stainless steel cleaner/ polish is maintained, stainless steel surfaces will retain their new, clean, polished appearance indefinitely. Use clean mild soapy water for powder coated units.
6. Periodically remove panels and clean out inline "Y" Strainer.

Pushfit Installation

Note: fittings and tube should be kept clean, bagged and undamaged prior to installation.

Figure 2

1. Cut to fit length of 1/4" PE Tubing and remove any burrs or sharp edges. Ensure that the outside diameter is free from score marks. Tube ends should be square.

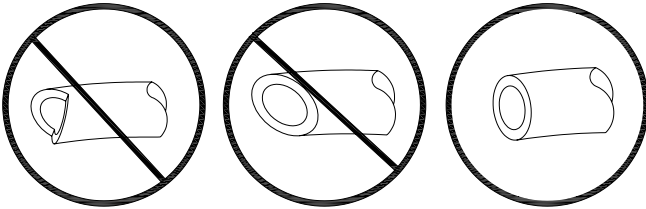

2. Firmly and fully insert the Tubing end into the Push-In Fitting up to the Tube Stop located approximately 1/2" [13mm] deep.

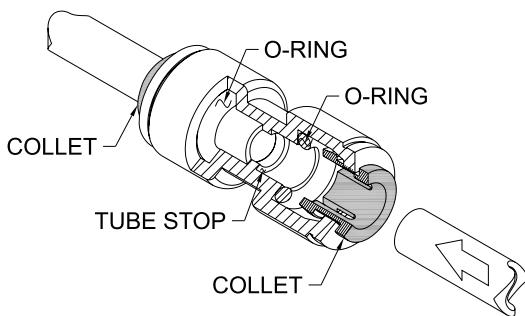

3. Pull on the fitted Tubing to ensure it is secure. Tube should not come free from the Fitting. Water test the connection assembly prior to leaving the site to ensure there are no leaks.

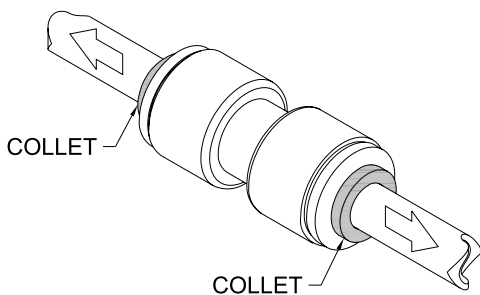

4. Prior to disconnecting the Tube from the Fitting, ensure that the Water Line is depressurized. Push Collet Square towards the Push-In Fitting Body and hold. While holding the Collet in, pull on the PE Tubing to remove from the Push-In Fitting.

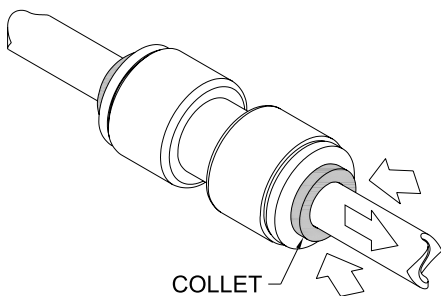



Note: This product should be installed, by suitably qualified persons, in a fit for purpose application, to suitable materials, using suitable fixings and comply with any relevant codes. It should be inspected periodically for signs of wear and tear that may affect performance or safety.

Dimensions are subject to manufacturer's tolerance of +/-10mm. Rough-in should be completed with each fixture.

Important: Installation Instructions are subject to change without notice.

Please visit **our websites** for latest revision.