

## MODELS

## RBA8910-SERIES

- RBA8910-00-series** Outdoor Drinking Fountain | Single Pillar
- RBA8910-20-series** Outdoor Drinking Fountain | Double
- RBA8910-30-series** Outdoor Drinking Fountain | Triple
- RBA8910-40-series** Outdoor Pet Fountain



\*RBA8910-002 shown



As improvements in the design and performance of RBA products are continuous, specifications may be subject to change without notice. The illustrations and descriptions herein are applicable to production as of the date of this Installation Instructions Sheet. Revised 08/24 © 2024 by RBA Group II/Model RBA8910-series/0824

## Installation for RBA8910-00-series

1. Provide 750mm square x 150mm deep minimum concrete slab [by others] to securely anchor fixture. Install four concrete anchors [by others] at dimensions shown to match holes in fixture base.
2. Rough-in waste outlet for 40mm and water supply within 150mm diameter bottom opening. Stop tap recommended on supply [by others].
3. Carefully remove the fixture and components from the packaging preventing scratching and damage.
4. Remove back access panel from fixture pedestal. Ensure push button, waste piping, and bubbler are secure and check all the tubing connections to make sure they did not come loose in shipment.
5. Set pedestal in place aligning base holes with the installed anchors and secure with M12 or 1/2" bolts [by others].
6. Make-up waste connection to the waste piping [trap by others].
7. Flush water supply [by others] of all debris prior to connection to fixture.
8. Connect water supply [by others] to 1/2" BSP inlet.
9. Test operation of bubbler by depressing button. Adjust the flow rate as required. Refer to troubleshooting. Check all connections and waste piping.
10. Reinstall access panel.

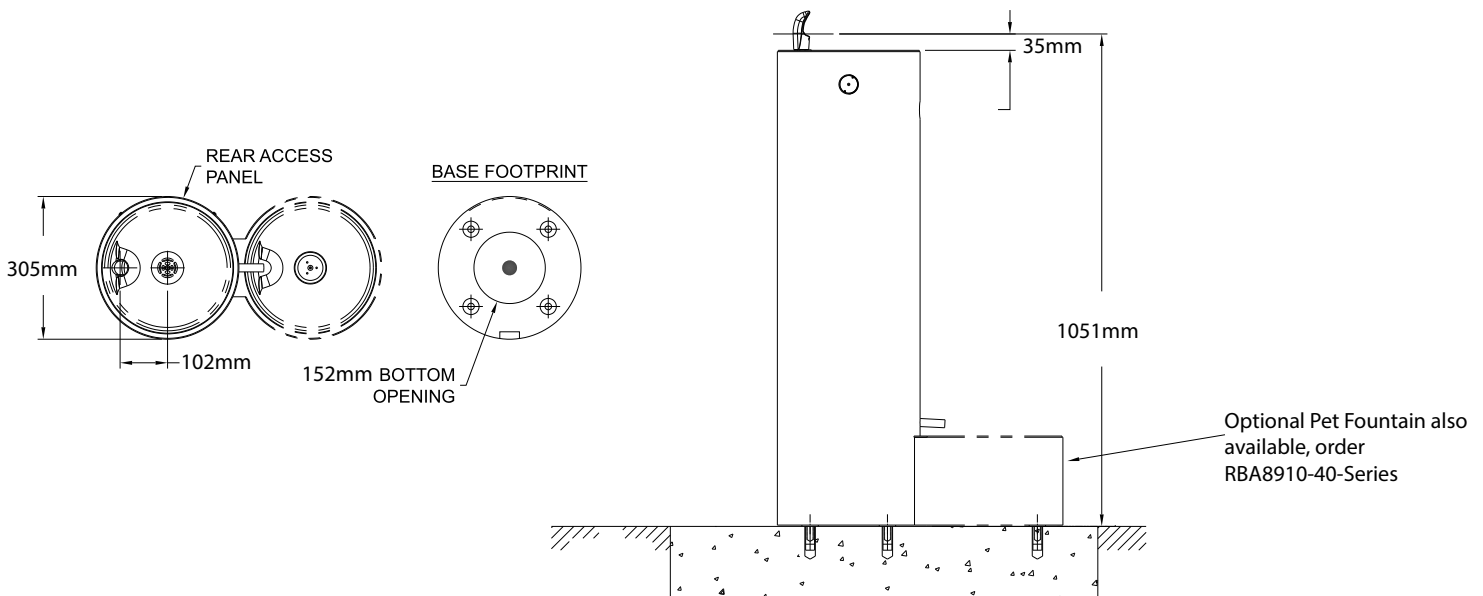

## Installation for RBA8910-20-series

1. Provide 750mm square x 150mm deep minimum concrete slab [by others] to securely anchor fixture. Install four concrete anchors [by others] at dimensions shown to match holes in fixture base.
2. Rough-in waste outlet for 40mm and water supply within 150mm diameter bottom opening. Stop tap recommended on supply [by others].
3. Carefully remove the fixture and components from the packaging preventing scratching and damage.
4. Remove back access panel from fixture pedestal and bottom access panel from cantilever. Ensure push button, waste piping, and bubbler are secure and check all the tubing connections to make sure they did not come loose in shipment.
5. Set pedestal in place aligning base holes with the installed anchors and secure with M12 or 1/2" bolts [by others].
6. Make-up waste connection to the waste piping [trap by others].
7. Flush water supply by others of all debris prior to connection to fixture.
8. Connect water supply by other to 1/2" BSP inlet.
9. Test operation of bubbler by depressing button. Adjust the flow rate as required. Refer to trouble shooting. Check all connections and waste piping for leaks. Correct if present.
10. Re-install back access panel and bottom access panel.

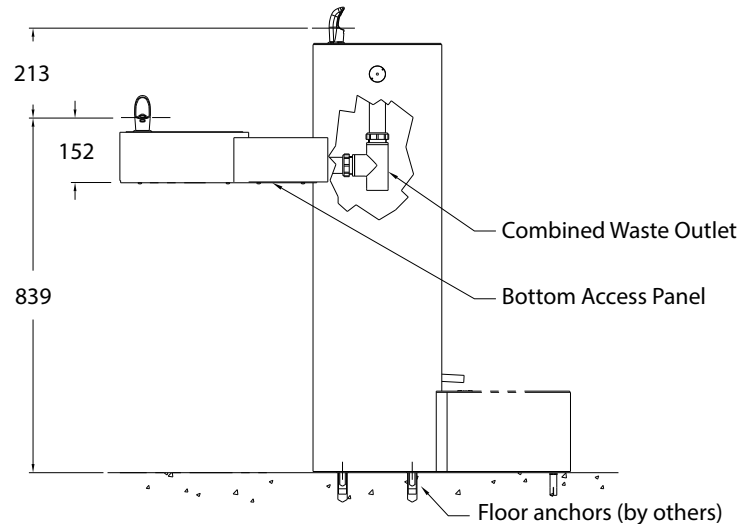
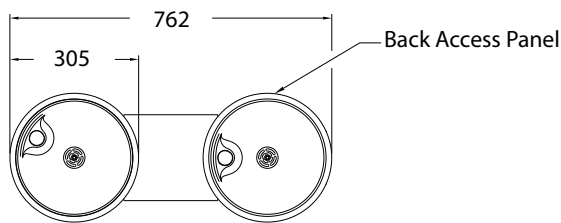

## Installation for RBA8910-30-series

1. Provide 750mm square x 150mm deep minimum concrete slab [by others] to securely anchor fixture. Install four concrete anchors [by others] at dimensions shown to match holes in fixture base.
2. Rough-in waste outlet for 40mm and water supply within 150mm diameter bottom opening. Stop tap recommended on supply [by others].
3. Carefully remove the fixture and components from the packaging preventing scratching and damage.
4. Remove back access panel from fixture pedestal and bottom access panel from cantilever. Ensure push button, waste piping, and bubbler are secure and check all the tubing connections to make sure they did not come loose in shipment.
5. Set pedestal in place aligning base holes with the installed anchors and secure with M12 or 1/2" bolts [by others].
6. Make-up waste connection to the waste piping [trap by others].
7. Flush water supply [by others] of all debris prior to connection to fixture.
8. Connect water supply [by others] to 1/2" BSP inlet.
9. Test operation of bubbler by depressing button. Adjust the flow rate as required. Refer to troubleshooting. Check all connections and waste piping for leaks. Correct if present.
10. Re-install back access panel and bottom access panel.

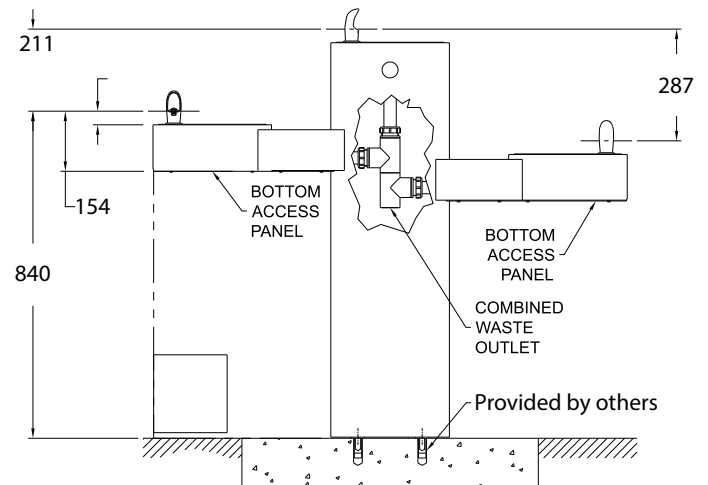
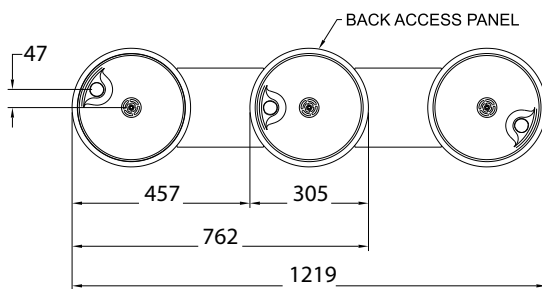

## Installation for RBA8910-40-series

1. Remove basin from fixture by removing screw at center of drain and separating from housing.
2. Provide 750mm square x 150mm deep minimum concrete slab [by others] to securely anchor fixture. Install 6 concrete anchors [by others] by using fixture as a template to locate and mark floor and wall anchoring.
3. Rough-in waste outlet for 40mm and water supply within 150mm diameter bottom opening. Stop tap recommended on supply [to be supplied by others]
4. Flush water supply [by others] of all debris prior to connection to fixture.
5. Connect water supply [by others] to 1/2" BSP supply inlet connection to Y-strainer.
6. Make-up waste connection to the waste piping [trap by others]
7. Secure fixture to wall and floor using hardware [supplied by others]. Secure basin to fixture.
8. Test operation of bubbler by depressing button. Adjust the flow rate as required. Refer to troubleshooting. Check all connections and waste piping for leaks. Correct if present.

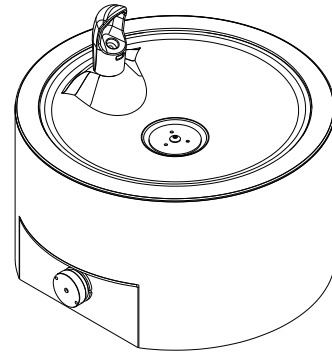
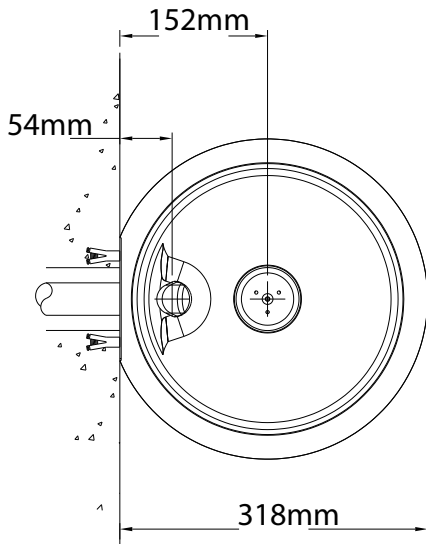

\* Valve specifications:  
Minimum/Maximum Pressure  
30 to 100 psi.

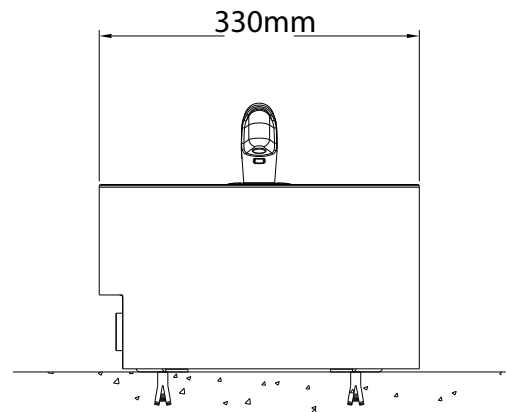
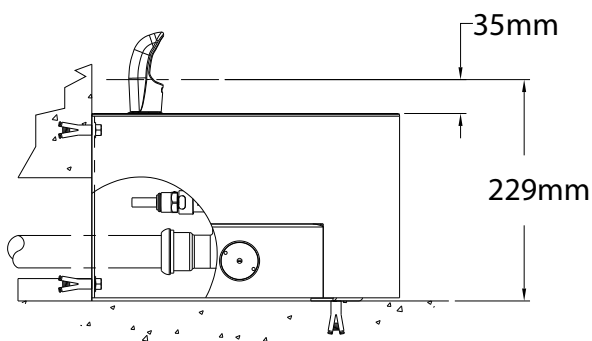

## Push Button Installation

Note: fittings and tube should be kept clean, bagged and undamaged prior to installation.

1. Cut to fit length of 1/4" PE tubing and remove any burrs or sharp edges. Ensure that the outside diameter is free from score marks. Tube ends should be square.

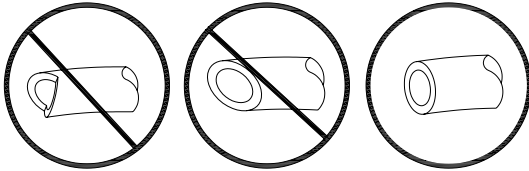

2. Firmly and fully insert the tubing end into the Push-In Fitting up to the tube stop located approximately 1/2" [13mm] deep.

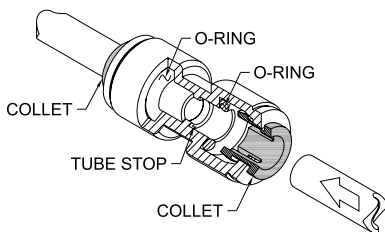

3. Pull on the fitted tubing to ensure it is secure. Tube should not come free from the fitting. Water test the connection assembly prior to leaving the site to ensure there are no leaks.

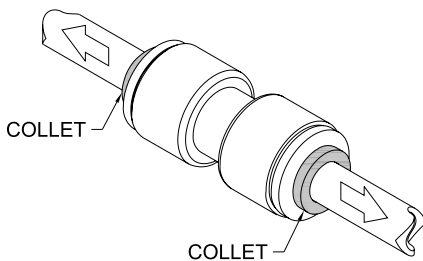

4. Prior to disconnecting the tube from the fitting, ensure that the Water Line is depressurised. Push collet square towards the push-in fitting body and hold. While holding the collet in, pull on the PE tubing to remove from the push-In fitting.

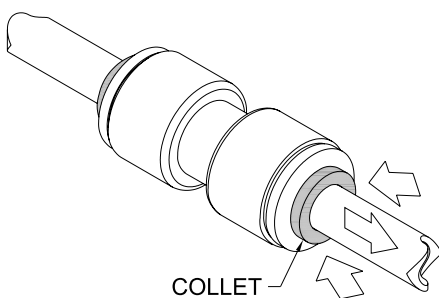

## Troubleshooting

Before making any of the repairs listed, make sure the water cooler is disconnected from the electrical supply and the water supply valve is shut off.

Problem	Probable cause
<b>Adjustments</b>	Cartridge – The water flow can be adjusted using a slotted narrow blade screwdriver and turning clockwise to increase flow and counterclockwise to decrease flow.
	Bubbler Stream - Bubbler can be rotated slightly to direct the stream backwards or forwards. Adjust the stream to minimise splashing. Splashing may occur from bubbler stream if the unit is not level. Shim lower mounting point, if necessary, to level chiller.
<b>Restricted Or No Water Flow</b>	Ensure water supply service stop valve is fully open.
	Verify minimum 200 kPa supply line flow pressure.
	Check for twists or kinks in outlet tubing.
	Check inline strainer for debris.
	Inspect bubbler for debris.
	Adjust flow rate.
<b>Water Drips Or Will Not Shut Off</b>	Replace cartridge.
	Open fixture. Loosen nuts holding valve bracket assembly to bottom of fixture but do not remove. Move complete valve bracket assembly further back from the front push pad and tighten to lock in place.
	Replace valve cartridge.

**Note:** This product should be installed, by suitably qualified persons, in a fit for purpose application, to suitable materials, using suitable fixings and comply with any relevant codes. It should be inspected periodically for signs of wear and tear that may affect performance or safety.

Dimensions are subject to manufacturer's tolerance of +/-10mm. Rough-in should be completed with each fixture. Important: Installation Instructions are subject to change without notice. Please visit our websites for latest revision.

