

Model RBA4090-911

Materials & Features

Stainless steel 90° WC grab rail to meet the requirements of AS1428.1 when installed correctly. Snap flange cover conceals fixings after installation.

Technical Detail

Rail 32mm [Dia], 304 Satin Stainless Steel
 Fixings Supplied



Available Model

RBA4090-911 90° Toilet Grab Rail | Right Hand

Related Products

RBA4000-040 Straight Grab Rail 400mm
RBA4090-901 90° Toilet Grab Rail | Left Hand
RBA4150-101 Accessible Compliant Backrest

Installation

Warning: Grab rails are no stronger than the anchors or walls to which they are attached and must be firmly secured in order to support the loads for which they are intended. Refer to local codes and Installation Instructions for location of fixing points, method of attachment, etc.

Important: Installation instructions and current rough-in details should be furnished with each fixture. Do not rough in without certified dimensions. Dimensions are subject to manufacturer's tolerance of +/-10mm.

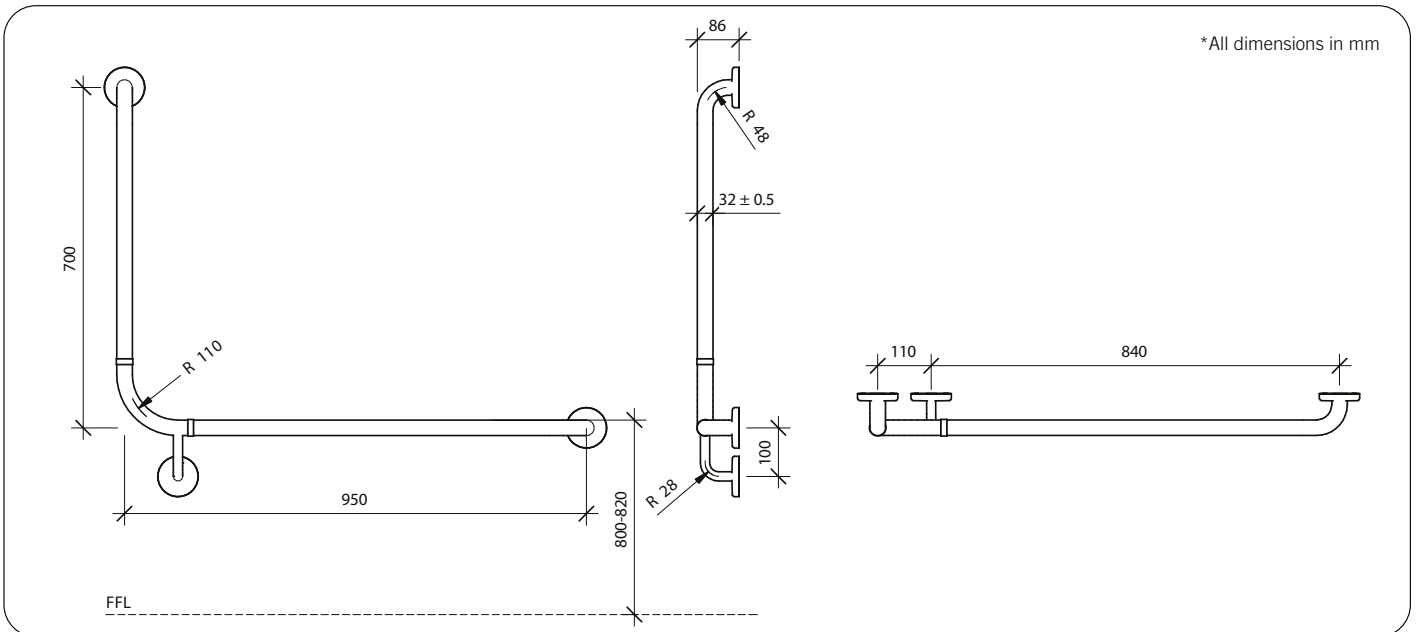

As improvements in the design and performance of RBA products are continuous, specifications may be subject to change without notice. The illustrations and descriptions herein are applicable to production as of the date of this Technical Data Sheet. Revised 01/24 © 2024 by RBA Group TD/Model RBA4090-911/0124