

MODELS

- RBA8851-100**
- RBA8851-156**
- RBA8851-428**

STAINLESS STEEL TOILET

- Stainless Steel WC | No Seat
- Stainless Steel WC | Ambulant | With Seat & Lid | S-Trap
- Stainless Steel WC | Accessible | With Seat, No Lid



*RBA8851-428 pictured



As improvements in the design and performance of RBA products are continuous, specifications may be subject to change without notice. The illustrations and descriptions herein are applicable to production as of the date of this Installation Instructions Sheet. Revised 08/24 © 2024 by RBA Group II/Model RBA8851-series/0824

Components supplied

- P-Trap stainless steel pan [incl. with RBA8851-100 & -428]
- S-Trap stainless steel pan [incl. with RBA8851-156]
- S-Trap converter [incl. with RBA8851-100 & -428]
- M12 fixing rods with nuts & washers [incl. with RBA8851-100 & -428]
- Plastic seat with lid [incl. with RBA8851-156]
- Plastic seat without lid [incl. with RBA8851-428]
- S-Clip
- Security bit

Components supplied by others

- 40mm PVC Flush Pipe + Geberit Kee Seal 119.668.00.1

Pre-Installation

Installation must be undertaken in accordance with the PCA [Plumbing Code of Australia], AS/NZS3500.1 and AS/NZS3500.2. Where multiple WC's may be installed, correct hydraulic water supply sizing must be undertaken to ensure that each flushing device servicing each WC is able to operate correctly under probable simultaneous demand. A minimum water supply pressure of 300kPa is required for flushing device installation along with a minimum 25mm Cu or equivalent water supply line size for single flushing device installation only.

Pan is wall faced and should preferably be fixed to a masonry wall with suitable wall anchors [provided by others]. The RBA8851-100 & -428 are supplied with an S-Trap converter to allow installation as either an S-Trap or a P-Trap.

Flushing device should be RBA Nautilus Flush Valve [RBA1882-100] or equivalent flush valve or in-wall cistern.

Installation

1. Check supplied toilet against rough-ins provided in the installation instructions.
2. Remove access panels and place them in a safe area. When installing multiple toilets, make sure to identify which access panel matches which pan.
3. If not pre-formed, make sufficient penetrations through the wall and/or floor, as determined from the drawing, to allow the 100mm waste pipe and flush pipe [provided by cistern or flush valve manufacturer] to pass through.
 - a. If rear fixed, 4 threaded nuts are located in the rear of the toilet to allow for suitable M12 rods to pass through.
 - b. If front fixed, use suitable wall anchors [by others].
4. Determine floor mounting location by mocking up.
5. Fix the S-Clip to the floor in a location determined from the drawing.
6. For P trap installation, fit a 100 mm pan collar to the outlet with sufficient 100 mm pipe to extend through the wall. [Alternately the waste and flush pipes may be pre-plumbed and the pan pushed onto the pipework].
7. For S-Trap installation, location of floor penetration should be determined from the drawing.
8. Fit a 55mm kee seal [supplied by others].

Continued to next page...

Continued from previous page...

9. Push pan into position and secure the pan to the wall & floor [fixings by others].
10. Make the necessary connections to the waste and install the flushing device according to the manufacturer's instructions.
11. Check for leaks and correct flush volumes.
12. If toilet seat is required, unscrew plug bolts and fit the seat to pre-drilled holes.
13. Replace access panels.

Dimensions & Rough In

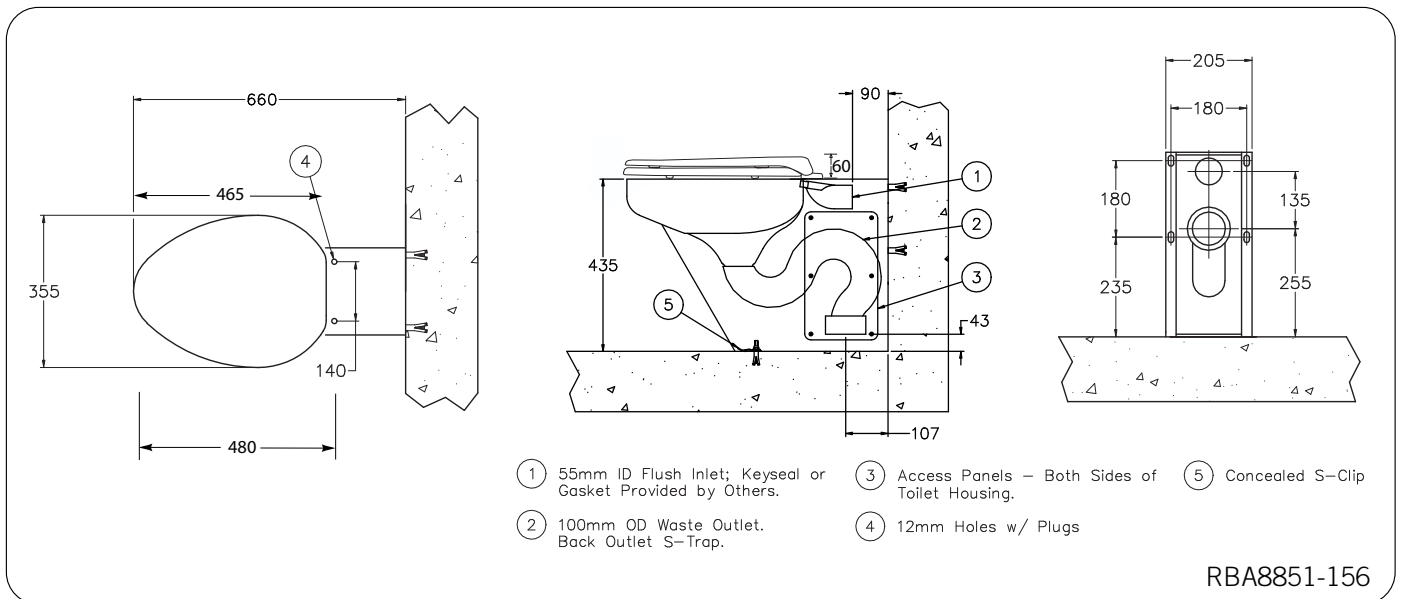
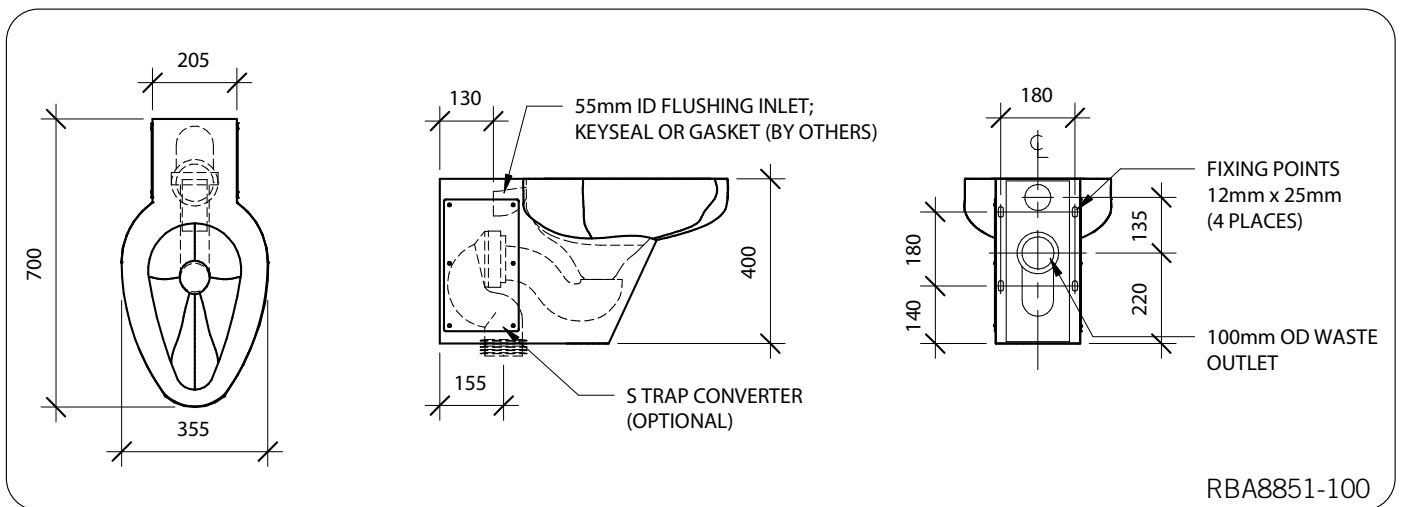

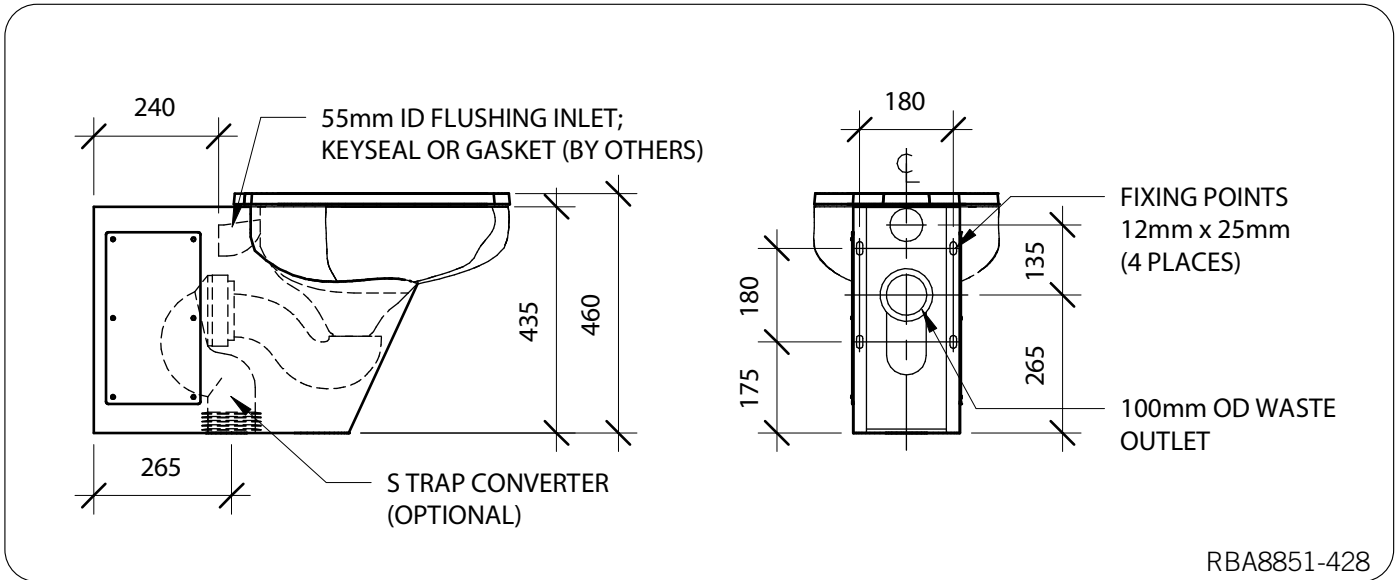

Note: This product should be installed, by suitably qualified persons, in a fit for purpose application, to suitable materials, using suitable fixings and comply with any relevant codes. It should be inspected periodically for signs of wear and tear that may affect performance or safety.

Dimensions are subject to manufacturer's tolerance of +/-10mm. Rough-in should be completed with each fixture.

Important: Installation Instructions are subject to change without notice.

Please visit **our websites** for latest revision.