

MODELS

COOGEE SENSOR TAP

- RBA1311-200**
- RBA1311-500**
- RBA1311-600**

- Coogee Spout Sensor Tap | Wall Mount | Chrome [shown]
- Coogee Spout Sensor Tap | Wall Mount | PVD Brushed Brass
- Coogee Spout Sensor Tap | Wall Mount | PVD Gunmetal



As improvements in the design and performance of RBA products are continuous, specifications may be subject to change without notice. The illustrations and descriptions herein are applicable to production as of the date of this Installation Instructions Sheet. Revised 08/24 © 2024 by RBA Group II/Model RBA1311-series/0824

Description

Constructed from lead-free DZR Brass with either a polished chrome finish [RBA1311-200], a PVD Brushed Brass finish [RBA1311-500] or a PVD Gunmetal finish [RBA1311-600]. The Coogee Sensor tap is wall mounted, making it suitable for public washrooms, offices, schools, shopping centres, stadiums, airports & accessible installations. The infrared sensor detects the presence of the user's hands in the field directly in front of the sensor in the water stream - this activates the flow of water until the hands are removed from the field and water will stop flowing immediately.

Technical Data

Inlet:	½" BSP
Operating Pressure:	200-500 kPa
Max Temperature:	45°C
Flow Rate:	6L per minute
Sensor Range:	5-30cm, self-setting
Power Supply [AC]:	230V AC 50-60Hz
Alternative Power Supply [DC]:	4 x 1.5V AA alkaline batteries

Components Supplied

- Plastic in-wall box.
- Tap body.
- Control housing unit.
- Flex hose.

Dimensions

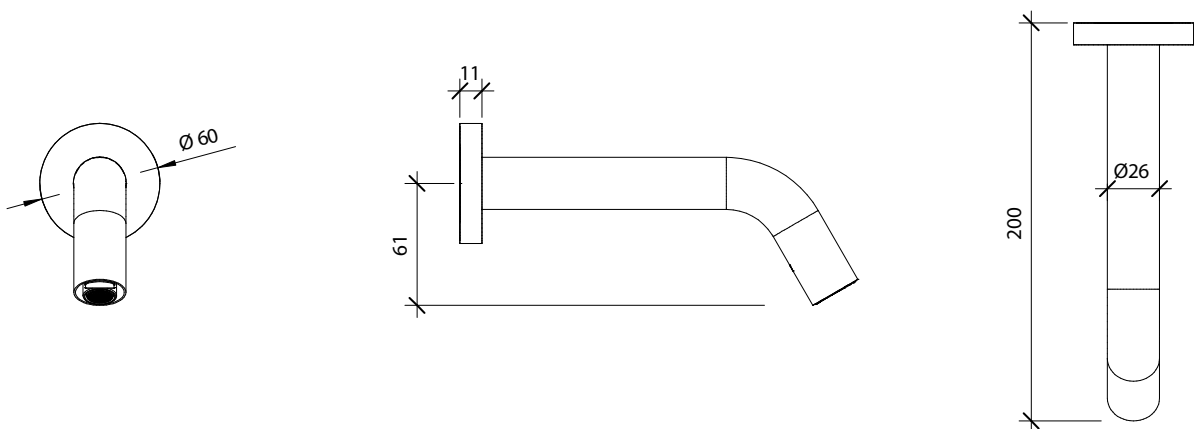

Note

1. Avoid exposure to direct sunlight.
2. Avoid harsh cleaning chemicals. Only clean with a soft, clean microfibre cloth with mild soap and water. For more information refer to our Warranty, Cleaning & Care Guide.
3. This product should be installed, by suitably qualified persons, in a fit for purpose application, to suitable materials, using suitable fixings and comply with any relevant codes. It should be inspected periodically for signs of wear and tear that may affect performance or safety.
4. Dimensions are subject to manufacturer's tolerance of +/-10mm. Rough-in should be completed with each fixture.

Important: Installation Instructions are subject to change without notice. Please visit our websites for latest revision.

Installation Notes

- When Thermostatic Mixing Valves or Tempering Valves are installed to supply warm water to the inlet of the Sensor Tap, if the heated water supply to these valves is from a Mains Pressure Water Heater, excess pressure on the heated water supply line can occur during the Water Heater's heating cycle which may be as high as 1400kPa subject to the Pressure and Temperature Relief Valve fitted to the Water Heater. Non return valves are fitted to Thermostatic Mixing Valves and Tempering Valves on both the heated and cold water inlets. As expansion occurs internal of the Water Heater during the heating cycle, the heated water line may pressurise through either valve resulting in a pressure lock occurring at the internal solenoid of the Tap. This may result in the tap ceasing to operate as intended. Should this occur, isolate the heated and cold water supply lines and disconnect the flexible hose connection on the warm water line to the tap to release the excessive pressure. Reinstall the flexible hose connection, check for leaks and actuate the tap to verify operation. Alternatively, the installation of a Pressure Reducing Valve on the warm water line supplying the Bronte may prevent such a pressure lock occurring.
- Please leave this documentation with the owner of the fixture when finished.
- Please read the entirety of this booklet before commencing installation. Check your installation for compliance with relevant local standards.
- Unit is to be installed in accordance with the Plumbing Code of Australia [PCA] and AS/NZS3500. Recess bodies are to be Watermark certified to AS3688. Heated water installations for sanitary fixtures shall comply with the temperature requirements of the PCA and AS/NZS3500.
- All wall penetrations in wet areas are to be in accordance with NCC Vol.2: Wet Areas.

Installation Instructions - Control Housing

1. Find a suitable location for the control housing within reach of desired tap location, GPO and stop valve [by others].
2. Remove the plastic control housing bracket from the rear of the unit and install into the wall using suitable fixings [by others].
3. Slide the control housing onto the bracket.
4. Turn on water supply and flush the supply line to remove all foreign debris. Turn off water supply.
5. Connect flex hose from control housing to supply line.

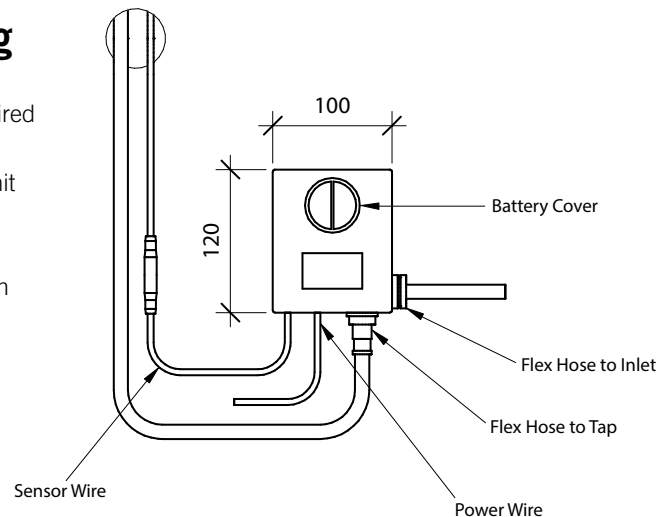

Installation Instructions - Tap

1. Check supplied tapware against rough-ins provided above.
2. Install the in-wall box such that the rear of the box will be seated 70-85mm from finished wall with the white connector piece protruding as per the requirements of NCC Vol. 2: Wet Areas.
3. Once the wall is finished, remove and discard the white connector piece.
4. Push the hose and wiring through the in-wall box. Retrieve them from the wall where the control housing is to be located.
5. Carefully unscrew the escutcheon from the tap body and remove, ensuring the O-ring seal remains firmly in place. Place the escutcheon in a safe location.
6. Loosen the four grub screws to release the fixed connector.
7. Apply suitable thread locker to the fixed connector and install into the in-wall box so that the wider threaded ring is ~5mm proud of finished wall.

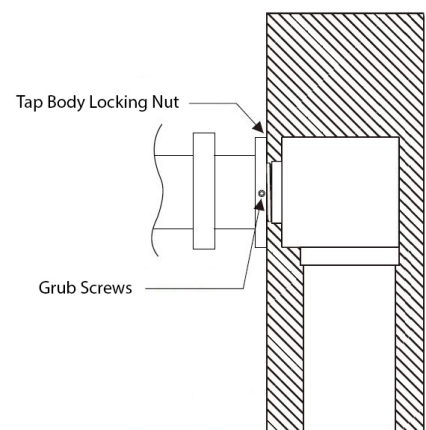
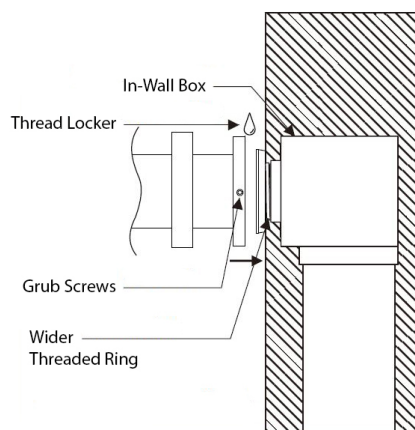
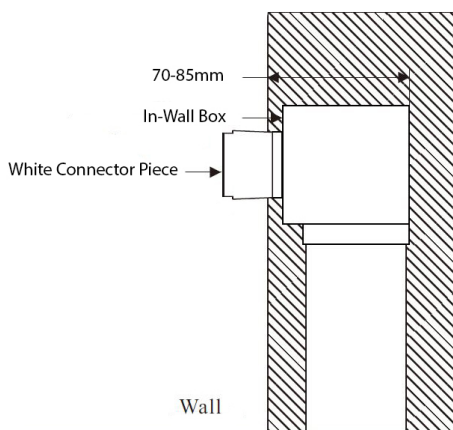

8. Reinstall the tap body back onto the fixed connector and tighten the four grub screws.
9. Carefully reinstall the escutcheon and seal as per the requirements of NCC Vol. 2: Wet Areas. For high-traffic areas, apply a suitable thread locker.
10. Connect flex-hose from tap to the control housing.
11. Turn on water supply and check for leaks in supply hose line before connecting the power supply.
12. Connect sensor wire to tap.
13. Connect control housing power supply to GPO [by others] and/or insert batteries into the battery container [see below].
14. Once powered, the sensor will automatically adjust its sensor range to suit the installation. This can take up to two minutes.

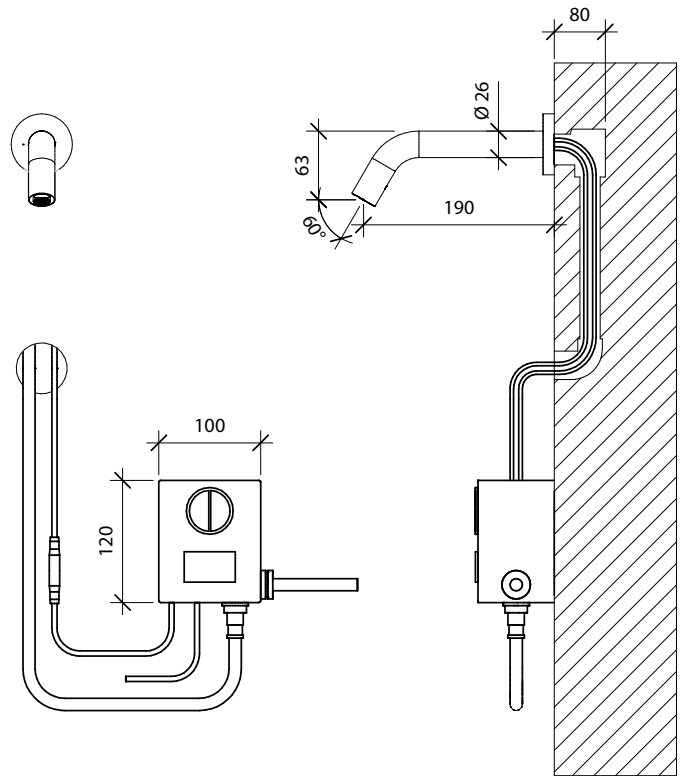

Battery Operation

All RBA Coogee sensor taps can run as mains power or from 4 x AA batteries.

1. To add batteries, turn the battery box counter-clockwise and remove.
2. Replace the batteries, reinsert the battery box and secure by turning clockwise.

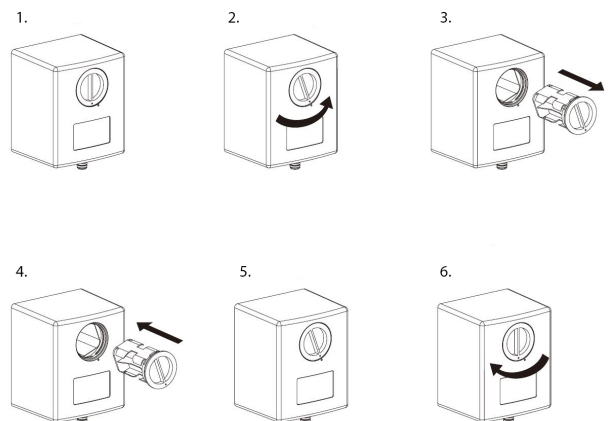

Troubleshooting

Problem	Probable Cause	Solution
Water does not flow when hands are placed under the sensor.	No/Insufficient power.	Ensure the power cord is properly connected and has not been damaged.
	Closed water supply line.	Ensure the stop cock is fully open and working as intended.
Slow flow rate.	Partially open water supply valve.	Fully open the water supply valve.
	Incorrect water pressure.	Check whether water supply line pressure is between 200 - 500kPa. If necessary, install a pressure limiting valve.
	Poorly connected flex hose.	Check whether the hose is kinked. Correct, if necessary.
	Dirty aerator.	Remove and clean aerator.
Water does not stop flowing.	Dirty sensor.	Clean the surface of the sensor with a mild soap.
	Object in front or within sensors range.	Remove object.
	The battery is dead.	Replace the batteries or switch to mains power.
Water flows [intermittent failures or incorrect function]	Highly reflective surface.	Unit not recommended for use with high polished stainless steel basins (satin finish OK). Place dull coloured strip opposite sensor.
	Hands too low or high in basin & not directly in front of sensor when in use.	Users to place hands in flow stream directly in front of sensor to correctly activate
Water droplets appearing under the basin.	Gasket improperly installed or damaged.	Realign or reinstall new gasket.