

MODELS

AMBULANT TOILET SUITE

RBA8847-156

Ambulant Toilet Suite S-Trap with Seat

RBA8847-157

Ambulant Toilet Suite P-Trap with Seat



*RBA8847-157 Shown



As improvements in the design and performance of RBA products are continuous, specifications may be subject to change without notice. The illustrations and descriptions herein are applicable to production as of the date of this Installation Instructions Sheet. Revised 03/24 © 2024 by RBA Group II/Model RBA8847-156-RBA8847-157/0324

Description

Unit is highly vandal resistant, front fixed and is manufactured from stainless steel. External surface is satin finish. Internal bowl is matte finish for hygiene, easy cleaning and scale resistance. The integrated seat is bright polished for hygiene and comfort. Laser-cut, flush-fitting access panels on both sides are fixed with security screws.

Components Supplied

- WC Pan
- Caroma Invisi 2 Cistern
- Cistern Cover
- Buttons
- Toilet Seat with Lid

Components Supplied by Others

- Wall/floor anchors
- Kee Seal [Geberit 119.668.00.1]
- ½" Mini Cock

Installation

Installation must be undertaken in accordance with the PCA [Plumbing Code of Australia], AS/NZS3500.1 and AS/NZS3500.2. Where multiple WC's may be installed, correct hydraulic water supply sizing must be undertaken to ensure that each flushing device servicing each WC is able to operate correctly under probable simultaneous demand.

1. Remove the access panels in the sides of the pan using the security bit provided. Install the pan using the S-clip provided to secure the pan to the floor.
2. Connect the waste.
3. Mount the cistern, secure to the wall (suitable anchors by others) and make the necessary water connections. Cistern flush volume has been modified to 6/3L in accordance with the manufacturer's instructions.
4. Install the cistern cover over the cistern and secure.
5. Check for correct operation and leaks.
6. Fit the seat and replace the access panels.
7. Suite should be installed only with the Caroma Invisi 2 Cistern.

**Dimensions & Rough In
RBA8847-156**

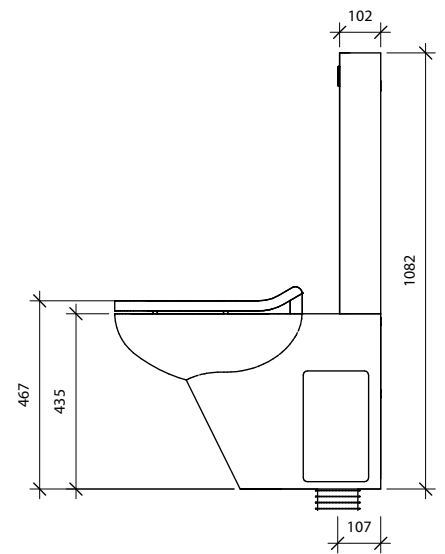
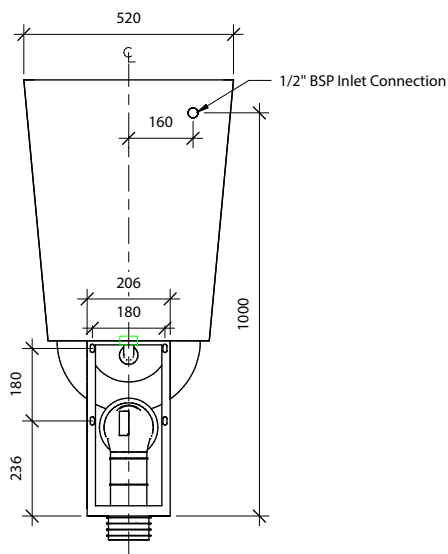
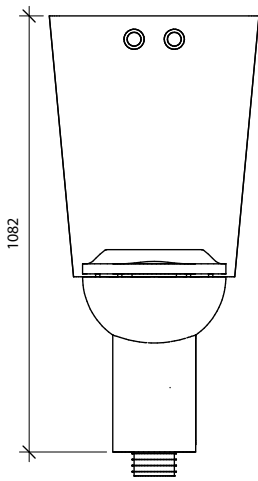
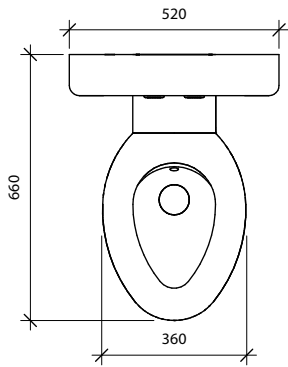

Dimensions & Rough In RBA8847-157

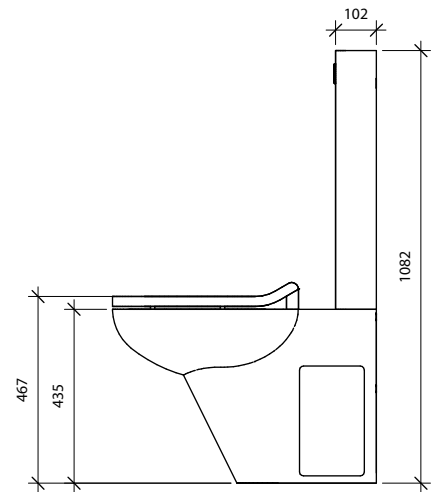
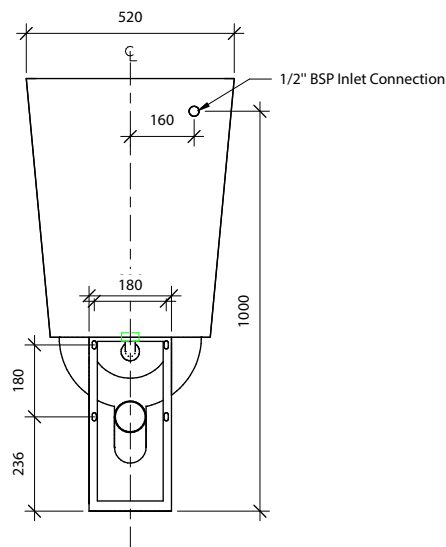
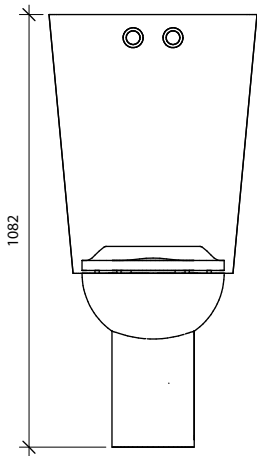
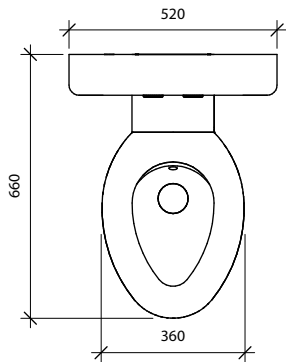

Note: This product should be installed, by suitably qualified persons, in a fit for purpose application, to suitable materials, using suitable fixings and to comply with any relevant codes. It should be inspected periodically for signs of wear and tear that may affect performance or safety.

Dimensions are subject to manufacturer's tolerance of +/-10mm. Rough-in should be completed with each fixture.

Important: Installation Instructions are subject to change without notice. Please visit **our websites** for latest revision.