

## Model RBA8900-429



### Materials & Features

Accessible Compliant to AS1428.2. Manufactured from stainless steel with all exposed surfaces in satin finish. Stainless steel, shielded bubbler with self-closing, push button and non-squirt features. Valve includes flow adjuster and strainer. Integral splashback and perforated drain for hygiene & ease of cleaning. Smooth radiused design eliminates sharp corners. Unit is non-refrigerated.

### Technical Detail

Inlet Connection:	G½B
Outlet Connection:	40mm BSP waste
Water Pressure:	200 – 500 kPa
Water Temperature:	4 - 30°C
Basin and Housing:	1.6mm, type 304 Stainless Steel
Force to Activate:	< 20N

### Available Models

**RBA8900-429** Accessible Wall Mounted Drinking Fountain

### Related Products

- RBA8901-102** Drinking Fountain, enclosed trap
- RBA2730-032** Compact Wall Mount Water Cooler
- RBA2750-031** Remote Chiller

**For best results,** unit should be inspected and cleaned regularly as per the instructions in the RBA Product Warranty, Cleaning Care Guide, available on our websites.  
**Important:** Installation instructions and current rough-in details should be furnished with each fixture. Do not rough in without certified dimensions. Dimensions are subject to manufacturer's tolerance of +/-10mm.

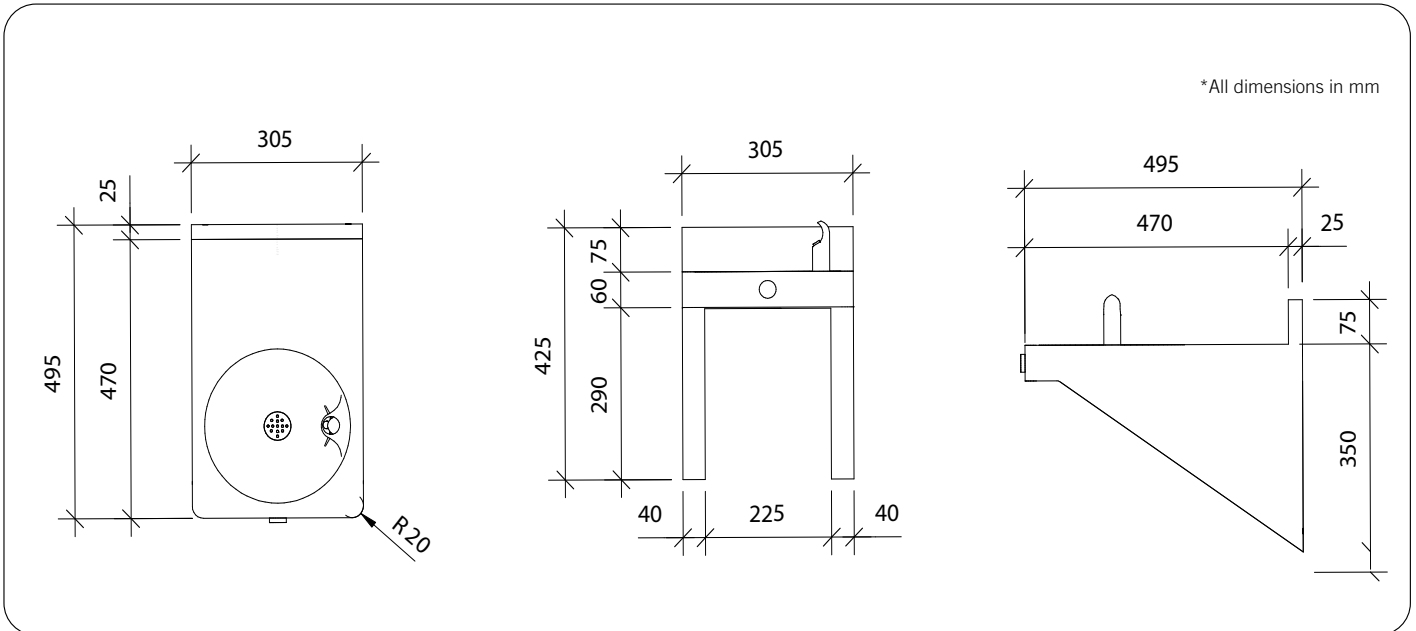

As improvements in the design and performance of RBA products are continuous, specifications may be subject to change without notice. The illustrations and descriptions herein are applicable to production as of the date of this Technical Data Sheet. Revised 07/22 © 2022 by RBA Group TD/Model RBA8900-429/0722