



### SPECIAL-ORDER REFLECTIVE SURFACES Specify Series Required:

#### Designer's Notes:

1. Special-order sizes available on request.
2. Mirror complies with Australian Standards AS1288-2006 when installed in accordance with the Standard.
3. Maximum size one-piece angle-frame mirror, 144" x 52" (366 x 132cm); minimum size, 12" x 12" (30 x 30cm).
4. All Bobrick framed mirrors are manufactured to overall width and height dimensions. EXAMPLE: A 24" x 36" (61 x 91cm) mirror will be furnished 24" x 36" (61 x 91cm) outside-of-frame to outside-of-frame.
5. To specify special sizes use Series Number followed by width then height in inches. EXAMPLE: B-2908 2024.
6. Bobrick framed mirrors are manufactured to a tolerance  $\pm 1/8"$  (3.2mm).
7. For sufficient space to lift mirror onto wall hanger(s), provide 3-1/4" (85mm) for Snap Locking Design; 5-3/8" (137mm) for "2S" Tab Design minimum clearance above center line of mounting screw holes.
8. Provide 1" (25mm) minimum clearance at bottom of mirror for unlocking mirror from wall and 1/2" (12.7mm) clearance on each side.



### SNAP LOCKING DESIGN (Rear View)

Figure: 1

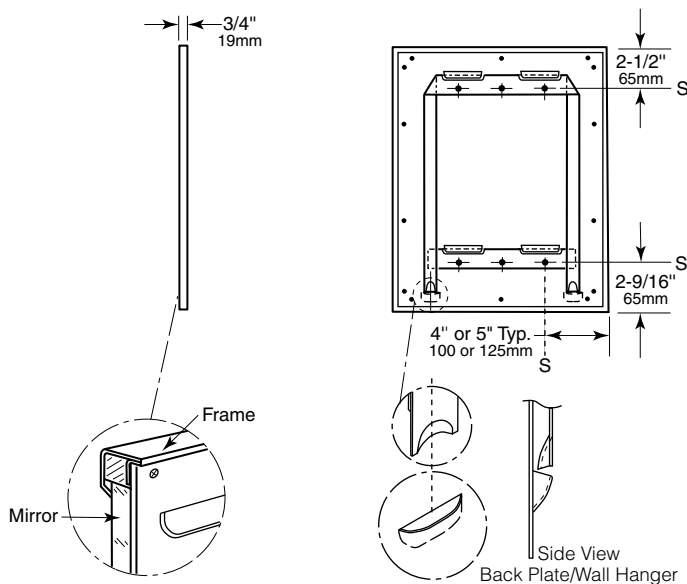

- B-2908 Series Tempered Glass Mirror  
Standard Sizes —

B-2908 1830	457 x 762mm
B-2908 1836	457 x 915mm
B-2908 2436	610 x 915mm

### S-Clip Design (Rear View)

- for all other mirrors up to a width of 36"

Figure: 2

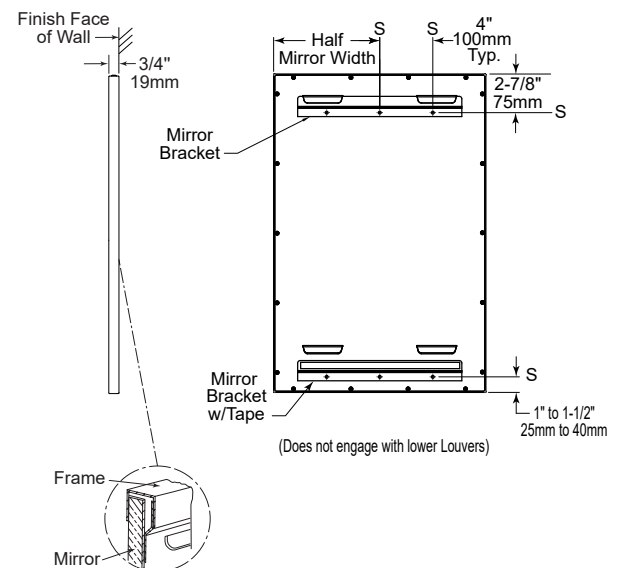

- B-2908 Series Tempered Glass Mirror —

B-2908 1639	406 x 991mm	Accessible Compliant: AS1428.1
B-2908 2430	610 x 762mm	
B-2908 2448	610 x 1219mm	
B-2908 2460	610 x 1524mm	
B-2908 2472	610 x 1829mm	

**Note:** Mirrors greater than 36" in width will have multiple hanger brackets with a typical 8" off each edge.

#### MATERIALS:

**Frame** — 18-8, Type-304, heavy-gauge stainless steel, 3/4" x 3/4" (19 x 19mm) angle with vertical-grain satin finish. One-piece, roll-formed construction forms continuous integral stiffener on all sides. Bevel design on front of angle holds frame tightly against mirror. Corners are welded, ground, and polished smooth. Galvanized steel back is fastened to frame with concealed screws and equipped with integral horizontal hanging brackets. Concealed Phillips-head locking screws securely fasten mirror to wall hanger(s).

continued . . .

*Designer's Note:* Type-304 stainless steel provides superior corrosion resistance, compared to 400 Series stainless steel, against environmental moisture, hose-down maintenance and strong cleaning solution.

**Mirror** — (B-2908 Series) No. 1 quality, 1/4" (6mm) tempered select float glass: selected for silvering and electrolytically copper-plated by the galvanic process.

**Note:** These reflective surfaces resist breakage and provide a measure of safety from broken glass, but differ in color and reflective quality from standard glass mirrors.

All edges protected by plastic filler strips. Backs of all glass mirrors are protected by full-size, shock-absorbing, water-resistant, nonabrasive, 3/16" (5mm) thick polyethylene padding.

**Concealed Wall Hanger** — For snap locking design: Heavy gauge steel construction. Incorporates upper and lower members, which engage backplate louvers to keep mirror against the wall. For "2S"-Tab design: Incorporates upper bracket engaging in upper louver and double sided tape below the bottom louver securing mirror to concealed wall hanger.

### INSTALLATION:

Mount wall hanger on wall with screws (not furnished) at points indicated by an S. For plaster or dry wall construction, provide backing to comply with local building codes, then secure wall hanger with screws (not furnished). When providing a concealed backing, allow backing to cover range of mounting hole locations shown on drawing. For other wall surfaces, provide fiber plugs or expansion shields for use with screws (not furnished), or provide 1/8" (3mm) toggle bolts or expansion bolts.

**Snap Locking Design:** Hang mirror on wall hanger with all four backplate louvers engaged behind horizontal wall hanger members. To do this, mirror must be centered in front of the wall hanger horizontally, pressed flat against the wall approximately 1" (25mm) above final position and then lowered into final position.

**S-Clip Design:** Comprises of two brackets, while the bottom one is furnished with double side tape. Bottom hanger bracket's mounting holes must be 1" - 1 1/2" above mirror's bottom edge. Note: Bottom hanger bracket is not supposed to engage with louvers of mirror's backplate. Hang mirror on wall top hanger bracket with the top two louvers engaged behind top wall hanger bracket. To do this, mirror must be centered in front of the wall hanger horizontally, pressed only at the top against the wall approx. 1" (25mm) above final position and then lowered into final position. When lowering, pull mirror's bottom edge off the wall by preventing bottom bracket from engaging. Once lowered, mirror must be pressed against wall to engage with double sided tape of lower wall hanger bracket.

**Snap Locking Design** — Locking devices automatically secure mirror to concealed wall hanger when it is lowered into final position (see figure 3). Locking devices may be unlocked by inserting two flat blade screwdrivers behind each side of mirror near the bottom or under the bottom of the mirror and pulling mirror bottom forward and then up.

**S-Clip Design** — Double-sided tape secures mirror to concealed wall hanger by pressing mirror against double sided tape of lower hanger once it is lowered into final position (see figure 4).

#### SNAP LOCKING DESIGN (Front View)

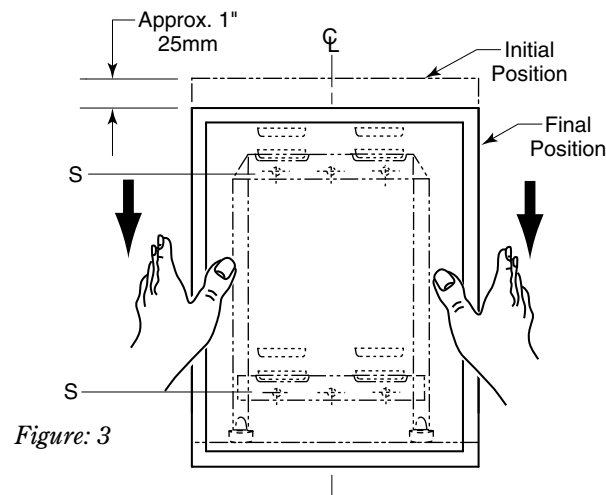

#### S-Clip Design- Up to 36" Width (Front View)

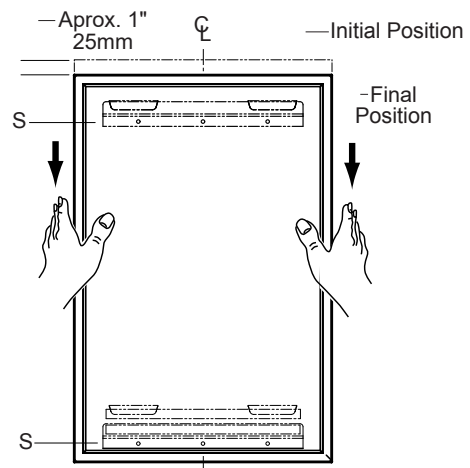

### SPECIFICATION:

Mirror shall have a one-piece Type-304 stainless steel angle frame, 3/4" x 3/4" (19 x 19mm) with continuous integral stiffener on all sides and beveled front to hold frame tightly against mirror; corners shall be welded, ground, and polished smooth; all exposed surfaces shall have satin finish with vertical grain. Mirror shall be \_\_\_\_\_ (insert one: polished stainless steel, tempered glass, or laminated glass). All edges shall be protected by plastic filler strips. Backs of all glass mirrors shall be protected by full-size, shock-absorbing, water-resistant, nonabrasive, 3/16" (5mm) thick polyethylene padding. Galvanized steel back shall have integral horizontal hanging brackets located at top for mounting on concealed rectangular wall hanger.

**Framed Mirror shall be Model \_\_\_\_\_ (insert model number) of Bobrick Washroom Equipment, Inc., Clifton Park, New York; Jackson, Tennessee; Los Angeles, California; Bobrick Washroom Equipment Company, Scarborough, Ontario; Bobrick Washroom Equipment Pty. Ltd., Australia; and Bobrick Washroom Equipment Limited, United Kingdom.**