

MODEL RBA8519-115

RBA8519-115

Coolum Commercial Shower Handle, with 3 colour temperature indicators [Red, Blue and Yellow]



As improvements in the design and performance of RBA products are continuous, specifications may be subject to change without notice. The illustrations and descriptions herein are applicable to production as of the date of this Installation Instructions Sheet. Revised 07/23 © 2023 by RBA Group II/Model RBA8519-115/0723

Technical Requirements

Body:	Chrome plated brass
SBA Thread:	G 5/8" BSP
Wall Depth:	12 - 22mm
Handle Rotation:	Quarter Turn
Water supply pressure:	100kpa – 500kpa in accordance with AS/NZS3500 and the PCA
Temperature:	5 - 70°C

- Please leave this documentation with the owner of the fixture when finished.
- Please read the entirety of this booklet before commencing installation. Check your installation for compliance with relevant local standards.
- Unit is to be installed in accordance with the Plumbing Code of Australia [PCA] and AS/NZS3500. Recess bodies are to be Watermark certified to AS3688. Heated water installations for sanitary fixtures shall comply with the temperature requirements of the PCA and AS/NZS3500.
- All wall penetrations in wet areas are to be in accordance with NCC Vol.2: Wet Areas

Components Supplied

- Quarter-turn ceramic SBA
- Handle assembly
- 3x colour indicators [red, blue, yellow]
- PTFE washer
- PTFE 3D washer
- 2.5mm security hex bit

Components Supplied by others

- Recess body

Tools Required

- Drill

Dimensional Drawing

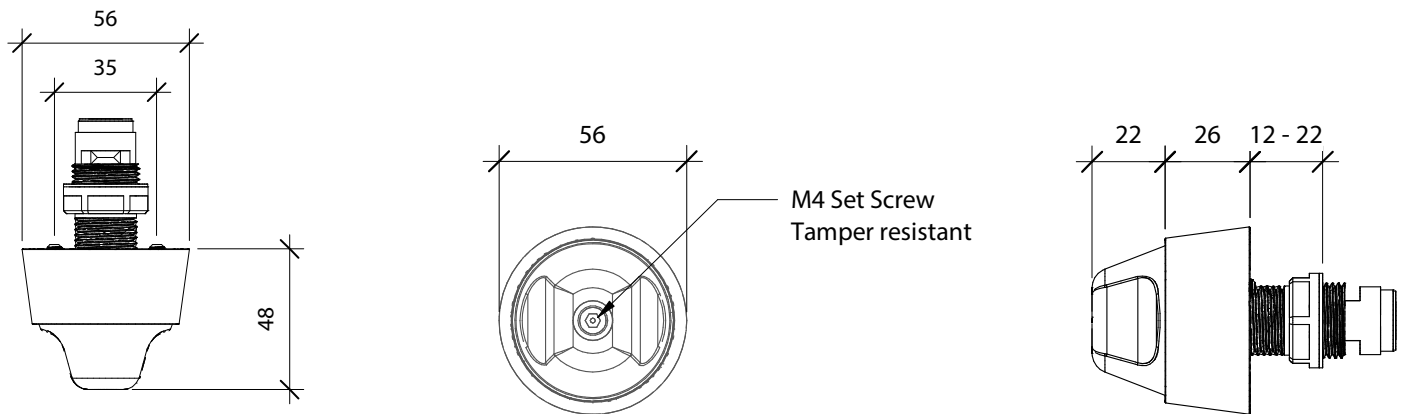

Installation Instructions

1. Ensure the recess body is undamaged and fitted such that it is parallel with, and 12mm to 22mm from the front of wall.
2. Remove the threaded adaptor and fibre washer from the SBA and screw into the recess body. Do not over tighten, as this will damage the seal at the base of the spindle.

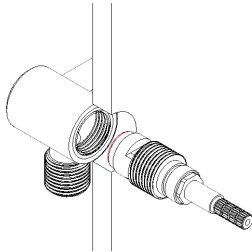

3. Fit the fibre washer and threaded adaptor and tighten firmly [ensure installation is done in accordance with AS3718].

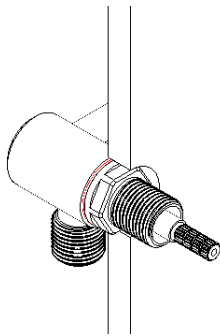

4. Run water through the unit to check for leaks
5. Fit the escutcheon onto the SBA and tighten until in position and flat against the wall.

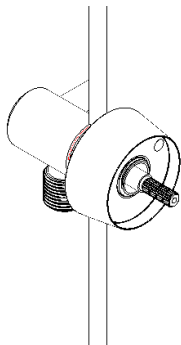

6. Mark the M5 holes and remove escutcheon.
7. Drill out holes to suit the locking M5 grub screws to minimum depth of 3mm.
8. Fit the escutcheon on the SBA and tighten the grub screws into holes in the wall.

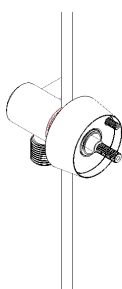

9. Measure and cut the spindle to 25-26mm from inside of escutcheon to end of spindle. If the spindle is too short due to wall depth, the supplied spacers may be used to extend the spindle.
 - a. To install one spacer, cut the spindle to 20-21mm and push the spacer into the handle spline prior to installation.
 - b. To install two spacers, cut the spindle to 15-16mm and push the spacers into the handle spline prior to installation.

Please note: The handle must be able to spin freely once installed without rubbing against the inside of the escutcheon



10. Install the 3D PTFE washer with ridges facing the escutcheon. Once in place, install the handle.
 - a. A second flat PTFE washer is supplied if an additional spacer is needed.

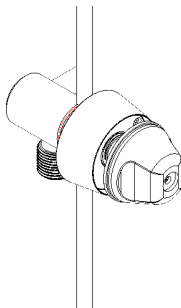

11. Insert the coloured ring into the cut-out in the top of handle [refer to AS/NZS3500 and any applicable local codes];
 - a. Blue for cold
 - b. Red for hot
 - c. Yellow for warm
12. Install the provided M4 screw into the top of handle and securely tighten [max torque of 2 Nm] using 2.5mm security hex bit [supplied].

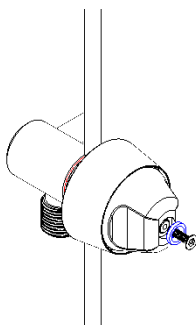

For best results, unit should be inspected and cleaned regularly as per the instructions in the RBA Product Warranty, Cleaning Care Guide, available on our websites.

Note: This product should be installed, by suitably qualified persons, in a fit for purpose application, to suitable materials, using suitable fixings and comply with any relevant codes. It should be inspected periodically for signs of wear and tear that may affect performance or safety.

Dimensions are subject to manufacturer's tolerance of +/-10mm. Rough-in should be completed with each fixture. **Important:** Installation Instructions are subject to change without notice. Please visit **our websites** for latest revision.