

# KOALA KARE PRODUCTS

## Installation and Operation Instructions

### KB101 and KB111-SSWM Baby Changing Station Cambiador Plegable Table à Langer Babywickelstation



You are responsible for the safe operation of this unit.

IMPORTANT. RETAIN FOR FUTURE REFERENCE. READ CAREFULLY.  
IMPORTANTE. GUÁRDELO PARA FUTURAS CONSULTAS. LEER ATENTAMENTE.  
IMPORTANT. À CONSERVER POUR INFORMATION. À LIRE ATTENTIVEMENT.  
WICHTIG. ZUR SPÄTEREN BEZUGNAHME AUFBEWAHREN. BITTE SORGFÄLTIG  
DURCHLESEN.



# OPERATING INSTRUCTIONS

**Please Note:**







To assure proper installation, it is suggested that a qualified person or carpenter install the Koala Baby Changing Station. Koala Kare Products will not be responsible if the station is not installed properly. Koala Baby Changing Stations have been tested to hold a substantial static load. The unit must be attached to a permanent wall that is capable of holding a substantial load. The maximum recommended total weight for this baby changing station (including baby and parcel bag) is 60 lbs. Excessive weight may cause a hazardous or unstable condition to exist.

**Restraint System:** To fasten the waist restraint strap, place strap around child’s midsection, and push spring tabs into buckle until both spring tabs lock in place with an audible “click”. Straps can be adjusted to make strap tighter or looser as required.

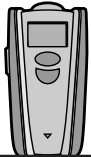
**Inspection Criteria:**

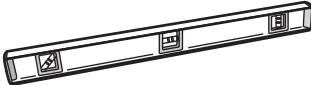
A properly maintained baby changing station:

- Opens and closes smoothly
- Has both ends of a functioning, non-frayed strap: buckle clicks when closed and strap is attached to unit at both ends.
- Offers parents liners through a fully stocked liner dispenser. (Dispenser built into unit.)
- Provides a clean, convenient place for customers to attend to their children.

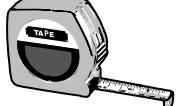
<b>TOOLS NEEDED</b>			
			Stud Finder 
Gloves 	Phillips Head Screwdriver 	Level 	Pencil 
Drill 	1/8” (3 mm) Drill Bit (regular and masonry) 	7/32” (6 mm) Drill Bit (regular and masonry) 	Measuring Tape 

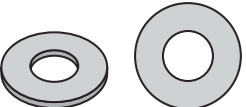
<b>HARDWARE PROVIDED</b>	
Four 1/4”x 3” (6 mm x 76 mm) Phillips Panhead Wood Screws 	Four 1/4” (6 mm) Flat Washers 

# INSTALLATION INSTRUCTIONS

## Vertical Baby Changing Station Surface Mounted Model Numbers KB101 and KB111-SSWM

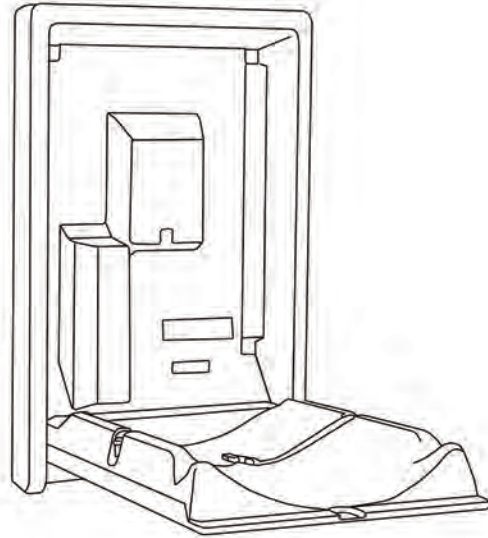
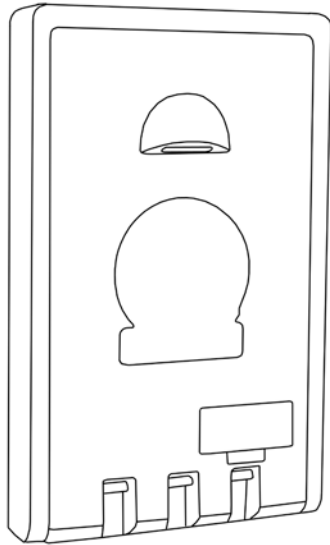

### Step 1.

Remove changing station from the shipping container and check for any freight damage. Identify the best location for installing the unit. Hold the unit in place and open the bed. Make sure you have taken the operating clearance into consideration.

### Step 2.

Determine the best method of mounting based on the type of wall. You may have left over hardware when you have finished installation.

### Step 3.

The vertical unit has four mounting holes provided in the back wall, positioned on a 16" (406 mm) stud center.

If possible, locate the wood or metal wall studs for fastening the unit in the desired location. If the walls do not have studs on center as outlined, make sure at least one side of the unit is installed into the stud.

# INSTALLATION INSTRUCTIONS

## Step 4.

Find the stud where you will be attaching the left side of the unit to the wall. Measure up from the floor 59" (1499 mm), at the center of the stud, and mark the wall. Mark remaining holes using a measuring tape to make sure the holes are precisely positioned. Hold unit in place to verify. Use four ¼" x 3" (6 mm x 76 mm) panhead wood screws with washers (supplied) when wall studs are available.

If the wall surface is masonry or tile over studs, use a 7/32" (6 mm) masonry drill bit for the pilot hole until you hit the stud. Change bit to 1/8" (3 mm) regular drill bit. Use four ¼" x 3" (6 mm x 76 mm) panhead wood screws with washers (supplied).

If the wall has wood studs that are not on 16" (406 mm) centers, has metal studs or an underlying surface of concrete block, drill with a ½" (13 mm) masonry bit. (You may have to purchase toggles before installing.) You must allow a minimum of inside wall space for toggles to turn depending on toggles used. Insert and tighten toggles.

## Step 5.

Position Koala sign (supplied) on the outside of the restroom door. Fill the built-in dispenser with sanitary bed liners. Replacement parts and additional liners can be purchased from your local distributor or by calling toll free 888.733.3456 or 303.539.8300 in the U.S.

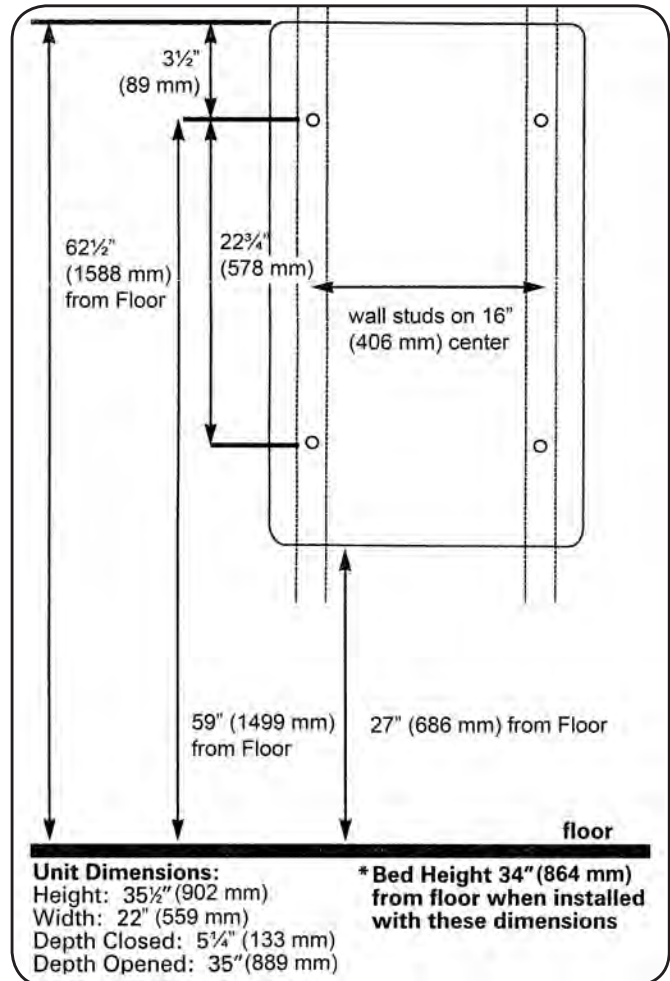

## ASTM F 2285-04(10)

 **WARNING:** Never leave child unattended.

 **WARNING:** Avoid serious injury from falling or sliding out. Always use restraint system.

 **WARNING:** Designed for Infants Only. Age up to 3.5 years and weighing less than 50 lbs. Keep one hand on the child at all times.

Parcels or accessory items, or both, placed on the unit may cause the unit to become unstable.

 **ATTENTION :** Ne laissez jamais un enfant sans surveillance.

 **ATTENTION :** Évitez les blessures occasionnées par une chute ou une glissade. Utilisez toujours le système de retenue.

 **ATTENTION :** Conçue uniquement pour les jeunes enfants. Jusqu'à 3 ans et demi et moins de 50 lb (23 kg). Conservez une main sur l'enfant à tout moment.

Tout paquet ou accessoire placé sur la table peut créer un déséquilibre.

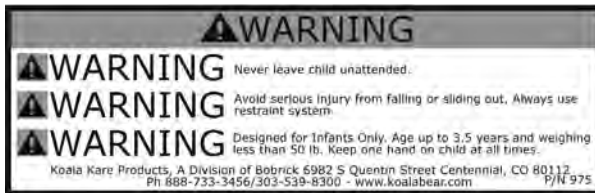



 **ADVERTENCIA:** No deje nunca al niño desatendido.

 **ADVERTENCIA:** Evite que el niño se lesione por caerse o resbalarse del cambiador Use siempre el sistema de sujeción.

 **ADVERTENCIA:** Diseñado exclusivamente para bebés. Hasta 3 años y medio de edad y con un peso inferior a 50 libras (22,5 kg aproximadamente). Mantenga siempre al niño sujeto con una mano. Colocar paquetes o accesorios, o ambas cosas, encima del cambiador puede provocar que se desestabilice.

 **WARNUNG:** Das Kind niemals unbeaufsichtigt lassen.

 **WARNUNG:** Ernsthafte Verletzungen durch Herausfallen oder Herausrutschen verhindern. Immer das Rückhaltesystem verwenden.

 **WARNUNG:** Dieses Produkt ist nur für Kleinkinder bis zu 3 1/2 Jahren und einem Gewicht von höchstens 50 lbs. (23 kg) vorgesehen. Das Kind immer mit einer Hand festhalten.  
Durch Ablegen von Päckchen und Zubehör auf der Wickelstation kann diese instabil werden.

