

Model RBA8910-402



*RBA8910-402 Shown

Materials & Features

Manufactured from stainless steel including a stainless shielded bubbler with self-closing push button and non-squirt features. Valve includes flow adjuster and strainer. Integral perforated drain for hygiene & ease of cleaning. Smooth radiused design eliminates sharp corners. Fully concealed pipework and fixings. Unit is non-refrigerated & foot operated.

Technical Detail

Inlet Connection:	G½B
Outlet Connection:	40mm BSP waste
Water Pressure:	200 – 500 kPa
Force to Activate:	≤ 22N
Basin:	1.2mm, type 304 Stainless Steel
Housing:	2.5mm, type 304 Stainless Steel
Finish:	Enviro-Glaze® green [-002 only]

Available Models

- RBA8910-402** Wall Mounted Pet Fountain, Enviro-Glaze® green
- RBA8910-401** Wall Mounted Pet Fountain, Stainless

Where required the Pet Fountain can be supplied on the following related products or as an optional round freestanding style bowl.

Related Products

- RBA8910-002** Outdoor Drinking Fountain, Enviro-Glaze® green
- RBA8910-202** Hi-Lo™ Outdoor Drinking Fountain, Enviro-Glaze® green

Important: Installation instructions and current rough-in details should be furnished with each fixture. Do not rough in without certified dimensions. Dimensions are subject to manufacturer's tolerance of +/-10mm.

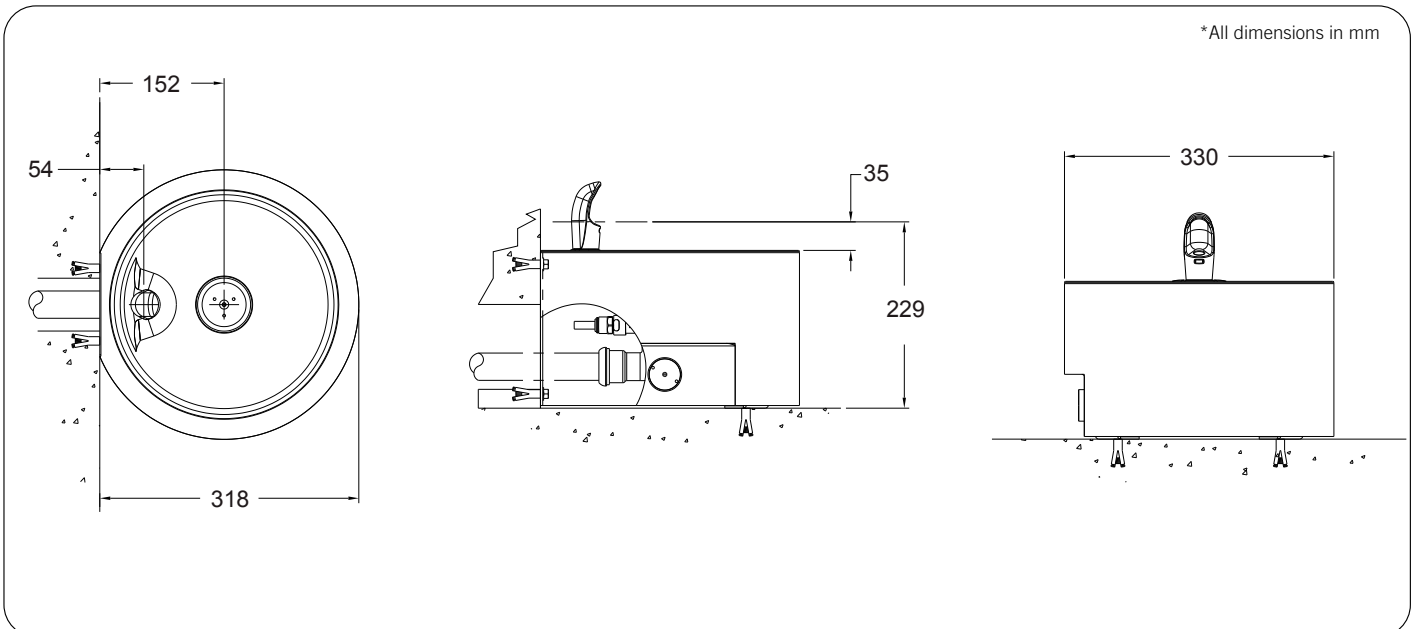

As improvements in the design and performance of RBA products are continuous, specifications may be subject to change without notice. The illustrations and descriptions herein are applicable to production as of the date of this Technical Data Sheet. Revised 03/22 © 2022 by RBA Group TD/Model RBA8910-402/0322